

TYPE DESCRIPTION

EuroProt+ DTRV type

TRANSFORMER PROTECTION & CONTROL



DOCUMENT ID: PP-13-21886
LAST VERSION: 1.0
2019-04-04, BUDAPEST

PROTECTION, AUTOMATION AND
CONTROL FOR POWER INDUSTRY



VERSION INFORMATION

VERSION	DATE	MODIFICATION	COMPILED BY
1.0	2019-04-04	First edition	Erdős, Tóth

CONTENTS

1	Introduction.....	4
1.1	Application.....	4
1.1.1	General features	4
1.2	Pre-defined configuration variants	5
1.3	Meeting the device	6
2	Function and I/O listing.....	7
3	Software configuration.....	8
3.1	Protection functions.....	8
3.1.1	Overexcitation protection function (VPH24).....	8
3.1.2	Definite time undervoltage protection function (TUV27)	12
3.1.3	Negative sequence overcurrent protection function (TOC46)	13
3.1.4	Negative sequence definite time overvoltage protection function (TOV47)	16
3.1.5	Line thermal protection function (TTR49L)	18
3.1.6	Three-phase instantaneous overcurrent protection function (IOC50)	21
3.1.7	Residual instantaneous overcurrent protection function (IOC50N)	22
3.1.8	Breaker failure protection function (BRF50)	23
3.1.9	Three-phase time overcurrent protection function (TOC51).....	25
3.1.10	Residual overcurrent protection function (TOC51N)	28
3.1.11	Residual definite time overvoltage protection function (TOV59N).....	31
3.1.12	Definite time overvoltage protection function (TOV59).....	32
3.1.13	Inrush detection function (INR68)	33
3.1.14	Three-phase directional overcurrent protection function (TOC67)	35
3.1.15	Switch-onto-fault preparation function (SOTF)	37
3.1.16	Residual directional overcurrent protection function (TOC67N)	39
3.1.17	Over-frequency protection function (TOF81)	42
3.1.18	Underfrequency protection function (TUF81)	43
3.1.19	Rate of change of frequency protection function (FRC81)	44
3.1.20	Directional over-power protection function (DOP32)	46
3.1.21	Directional under-power protection function (DUP32)	47
3.1.22	Restricted earth fault protection function (DIF87N)	48
3.1.23	Transformer differential protection function (DIF87_2w)	50
3.1.24	Automatic tap-changer controller function (ATCC).....	53
3.2	Control & supervision functions.....	60
3.2.1	Phase-selective trip logic (TRC94_PhS)	60
3.2.2	Circuit breaker wear monitoring function (CBWear)	62
3.2.3	Circuit breaker control function block (CB1Pol)	65
3.2.5	Disconnecter control function (DisConn)	68
3.2.6	Ethernet Links function (EthLinks)	70
3.2.7	Trip Circuit Supervision (TCS)	72
3.2.8	Dead line detection function (DLD).....	77
3.2.9	Voltage transformer supervision function (VTS60).....	78
3.2.10	Current unbalance function (VCB60).....	80
3.3	Measuring functions	82
3.3.1	Current input function (CT4)	84
3.3.2	Voltage input function (VT4)	87
3.3.3	Line measurement function (MXU).....	90
3.4	Disturbance recorder.....	96
3.5	Event recorder.....	99

1 Introduction

The **DTRV** product type is a member of the **EuroProt+** product line, made by Protecta Co. Ltd. The **EuroProt+** complex protection in respect of hardware and software is a modular device. The modules are assembled and configured according to the requirements, and then the software determines the functions. This manual describes the **DTRV** product type.

1.1 Application

The **DTRV** products are designed for protection and control applications of power transformers and generators including generator-transformer blocks (these generator applications are handled independently).

The main application field of the **DTRV** type here is power transformers of any type with any vector group, whether it be two- or three-winding transformers, autotransformers at MV and/or HV voltage level.

The relays of this type support double breaker terminals such as breaker and a half or ring bus topology.

The main protection functions of the **DTRV** type include differential protection, overcurrent protections for both (or all three) sides, and voltage and frequency-based protections.

Additionally, the **DTRV** product type incorporates the control of tap changers / automatic voltage regulators by dedicated configuration variants.

Because of the implemented control, measuring and monitoring function, the IEDs can also be used as a bay control unit.

The **EuroCAP configuration tool**, which is available free of charge, offers a user-friendly and flexible application for protection, control and measurement functions to ensure that the IED-EP+ devices are fully customizable.

1.1.1 General features

- Native IEC 61850 IED with Edition 2 compatibility
- Scalable hardware to adapt to different applications
- 84 HP or 42HP wide rack size (height: 3U)
- The pre-defined factory configuration can be customized to the user's specification with the powerful EuroCAP tool
- Flexible protection and control functionality to meet special customer requirements
- Advanced HMI functionality via color touchscreen and embedded WEB server, extended measuring, control and monitoring functions
- User configurable LCD user screens, which can display SLDs (Single Line Diagrams) with switchgear position indication and control as well as measuring values and several types of controllable objects.
- Various protection setting groups available
- Enhanced breaker monitoring and control
- High capacity disturbance recorder (DRE) and event logging (data is stored in non-volatile memory):
 - DRE for up to 32 analogue and 64 digital signal channels.
 - Event recorder can store more than 10,000 events.
- Several mounting methods: Rack; Flush mounting; Semi-flush mounting; Wall mounting; Wall-mounting with terminals; Flush mounting with IP54 rated cover.
- Wide range of communication protocols:
 - Ethernet-based communication: IEC61850; IEC60870-5-104; DNP3.0 TCP; Modbus TCP
 - Serial communication: DNP3.0; IEC60870-5-101/103; MODBUS, SPA

- The EuroProt+ family can handle several communication protocols simultaneously.
- Built-in self-monitoring to detect internal hardware or software errors
- Different time sources available: NTP server; Minute pulse; Legacy protocol master; IRIG-B000 or IRIG-B12X

1.2 Pre-defined configuration variants

The number and the functionality of the members of each product type is put together according to the application philosophy, keeping in mind the possible main usages. The available configurations of the DTRV type for transformers are listed in the table below.

VARIANT	MAIN APPLICATION
E0-Tr	Simplified protection for small transformers
E1-Tr	Two-winding transformer differential protection and control
E2-Tr	Two-winding transformer differential protection and control with voltage-based functions
E3-Tr	Two-winding transformer differential protection and control with voltage-based functions and automatic voltage regulator / tap changer controller
E4-Tr	Three-winding transformer differential protection and control
E5-Tr	Three-winding transformer differential protection and control with voltage-based functions
E6-Tr	Three-winding transformer differential protection and control with voltage-based functions and automatic voltage regulator / tap changer controller
E7-Tr	Automatic voltage regulator / tap changer controller

Table 1-1 The members of the DTRV type

Note that there are further members of the DTRV type, such as the E9, E10, E11 and E12 which are *generator protections* with several special functions, therefore they are handled separately from the ones listed here.

1.3 Meeting the device

Each configuration of has its own basic hardware arrangement according to the contained functions. The remaining free slots are filled up according to the user's requirements during ordering.

The technical specification of the hardware of the device (detailed descriptions of the modules, compliance to the IEC standards, etc.) is in the document "**Hardware description**" which can be found on the protecta website:

https://www.protecta.hu/protecta_open/fileOpen.php?documentation=10

The devices are made in two sizes, see the pictures below.



Figure 1-1 The 84HP (19") rack of **EuroProt+** family



Figure 1-2 The 42HP (1/2*19") rack of **EuroProt+** family

The basic information for working with the **EuroProt+** devices are described in the document "**Quick start guide to the devices of the EuroProt+ product line**" which can be found on the Protecta website:

https://www.protecta.hu/protecta_open/fileOpen.php?documentation=9

2 Function and I/O listing

The functions listed in Table 2-1 below are the ones that are present most commonly in the configurations, thus they can be considered as factory default arrangements. The hardware information corresponds to the maximum available number of digital I/O, and the default number of analog inputs.

For short descriptions for each function please refer to Chapter 3. Detailed information is available in their respective stand-alone descriptions on the Protecta website after logging in.

*The 'INST.' column contains the numbers of the pre-configured function blocks in the factory configuration. These numbers may be different in order to meet the user's requirements.

Transformer protection and control Automatic voltage regulator															
HARDWARE	FAMILY				EuroProt+										
	TYPE				DTRV										
	CONFIGURATION				E0	E1	E2	E3	E4	E5	E6	E7			
	CT inputs				4	8	8	8	12	12	12	4+4(op.)			
	VT inputs						4	4		4	8	4+4(op.)			
	Digital inputs (max)				128	112	112	112	100	100	88	128			
	Signaling relay outputs (max)				60	60	60	60	60	60	60	60			
	Fast Trip outputs (max)				12	12	12	12	12	12	12	12			
FUNCTIONALITY	Function name				IEC	ANSI	*INST.	E0	E1	E2	E3	E4	E5	E6	E7
	Overexcitation				V/Hz	24	1			✓	✓		✓	✓	
	Definite time undervoltage protection				U <, U <<	27	2	✓		✓	✓		✓	✓	✓
	Negative sequence overcurrent protection				I2 >	46	1	✓	✓	✓	✓	✓	✓	✓	
	Negative sequence overvoltage protection				U2 >	47	1	✓		✓	✓		✓	✓	
	Thermal protection line				T >	49	1	✓	✓	✓	✓	✓	✓	✓	
	Three-phase instantaneous overcurrent protection				I >>>	50	1	✓	✓	✓	✓	✓	✓	✓	
	Residual instantaneous overcurrent protection				Io >>>	50N	1	✓	✓	✓	✓	✓	✓	✓	
	Breaker failure protection				CBFP	50BF	1	✓	✓	✓	✓	✓	✓	✓	
	Three-phase time overcurrent protection				I >, I >>	51	2	✓	✓	✓	✓	✓	✓	✓	
	Residual time overcurrent protection				Io >, Io >>	51N	2	✓	✓	✓	✓	✓	✓	✓	
	Definite time overvoltage protection				U >, U >>	59	2	✓		✓	✓		✓	✓	✓
	Residual overvoltage protection				Uo >, Uo >>	59N	2	✓		✓	✓		✓	✓	
	Three-phase directional overcurrent protection				I Dir >, I Dir >>	67	2	✓							
	Switch onto fault preparation function						1	✓							
	Residual directional overcurrent protection				Io Dir >, Io Dir >>	67N	2	✓		✓	✓		✓	✓	
	Inrush detection and blocking				I2h >	68	1	✓							
	Overfrequency protection				f >, f >>	81O	2	✓		✓	✓		✓	✓	
	Underfrequency protection				f <, f <<	81U	2	✓		✓	✓		✓	✓	
	Rate of change of frequency protection				df/dt	81R	1	✓		✓	✓		✓	✓	
	Restricted earth fault				REF	87N	1	✓		✓	✓	✓	✓	✓	✓
	Transformer differential				3IdT >	87T	1		2w	2w	2w	3w	3w	3w	
	Automatic voltage regulator (AVR) / tap change control					90V	1				✓			✓	✓
Trip Logic					94		✓	✓	✓	✓	✓	✓	✓	✓	✓
Lockout trip logic					86		Op.	Op.	Op.	Op.	Op.	Op.	Op.	Op.	Op.
Bay control							✓	✓	✓	✓	✓	✓	✓	✓	
Circuit breaker wear							✓	✓	✓	✓	✓	✓	✓	✓	
Circuit breaker control							✓	✓	✓	✓	✓	✓	✓	✓	
Disconnecter control							✓	✓	✓	✓	✓	✓	✓	✓	
Ethernet Links							Op.	Op.	Op.	Op.	Op.	Op.	Op.	Op.	
Trip Circuit Supervision					74TC		✓	✓	✓	✓	✓	✓	✓	✓	
Fuse failure (VTS)					60	1			✓	✓		✓	✓	✓	
Current unbalance protection					60	1	✓	✓	✓	✓	✓	✓	✓	✓	
Current input							✓	✓	✓	✓	✓	✓	✓	✓	
Voltage input							✓	✓	✓	✓	✓	✓	✓	✓	
Line measurement							✓	✓	✓	✓	✓	✓	✓	✓	

Table 2-1 Basic functionality and I/O

3 Software configuration

3.1 Protection functions

3.1.1 Overexcitation protection function (VPH24)

The overexcitation protection function is applied to protect generators and unit transformers against high flux values causing saturation of the iron cores and consequently high magnetizing currents.

The flux is the integrated value of the voltage:

$$\Phi(t) = \Phi_0 + \int_0^t u(t) dt$$

In steady state, this integral can be high if the area under the sinusoidal voltage-time function is large. Mathematically this means that in steady state the flux, as the integral of the sinusoidal voltage function, can be expressed as

$$\Phi(t) = k \frac{U}{f} \cos \omega t$$

The peak value of the flux increases if the magnitude of the voltage increases, and/or the flux can be high if the duration of a period increases; this means that the frequency of the voltage decreases. That is, the flux is proportional to the peak value of the voltage (or to the RMS value) and inversely proportional to the frequency.

The overexcitation protection function is intended to be applied near the generator, where the voltage is expected to be pure sinusoidal, without any distortion. Therefore, a continuous integration of the voltage and a simple peak detection algorithm can be applied.

The effect of high flux values is the symmetrical saturation of the iron core of the generator or that of the unit transformer. During saturation, the magnetizing current is high and distorted; high current peaks can be detected. The odd harmonic components of the current are of high magnitude and the RMS value of the current also increases. The high peak current values generate high dynamic forces, the high RMS value causes overheating. During saturation, the flux leaves the iron core and high eddy currents are generated in the metallic part of the generator or transformer in which normally no current flows, and which is not designed to withstand overheating.

The frequency can deviate from the rated network frequency during start-up of the generator or at an unwanted disconnection of the load. In this case the generator is not connected to the network and the frequency is not kept at a “constant” value. If the generator is excited in this state and the frequency is below the rated value, then the flux may increase above the tolerated value. Similar problems may occur in distributed generating stations in case of island operation.

The overexcitation protection is designed to prevent this long-term overexcited state.

The flux is calculated continuously as the integral of the voltage. In case of the supposed sinusoidal voltage, the shape of the integrated flux will be sinusoidal too, the frequency of which is identical with that of the voltage. The magnitude of the flux can be found by searching for the maximum and the minimum values of the sinusoid.

The magnitude can be calculated if at least one positive and one negative peak value have been found, and the function starts if the calculated flux magnitude is above the setting value. Accordingly, the starting delay of the function depends on the frequency: if the frequency is low, more time is needed to reach the opposite peak value. In case of energizing, the time to find the first peak depends on the starting phase angle of the sinusoidal flux. If the voltage is increased continuously by increasing the excitation of the generator, this time delay cannot be measured.

As the heating effect of the distorted current is not directly proportional to the flux value, the applied characteristic is of inverse type (so called IEEE type): If the overexcitation increases, the operating time decreases. To meet the requirements of application, a definite-time characteristic is also offered in this protection function as an alternative.

The supervised quantity is the calculated U/f value as a percentage of the nominal values (index N):

$$G = \frac{\frac{U}{f}}{\frac{U_N}{f_N}} 100[\%] = \frac{\frac{U}{U_N}}{\frac{f}{f_N}} 100[\%]$$

The over-dimensioning of generators in this respect is usually about 5%, that of the transformer about 10%, but for unit transformers this factor can be even higher.

At start-up of the function, the protection function generates a warning signal aimed to inform the controller to decrease the excitation. If the time delay determined by the parameter values of the selected characteristics expires, the function generates a trip command to decrease or to switch off the excitation and the generator.

The time delay of the independent characteristic is

$$t(G) = t_{OP} \text{ when } G > G_S$$

where

t_{OP} (seconds) theoretical operating time if $G > G_S$, fix, according to the parameter *Min Time Delay* setting

G measured value of the characteristic quantity; this is the $\frac{U}{f}$ peak value as a percentage of the rated $\frac{U_N}{f_N}$ value.

G_S setting value of the characteristic quantity (Start U/f LowSet). This is the $\frac{U_{set}}{f_{set}}$ peak value as a percentage of the rated $\frac{U_N}{f_N}$ value.

The reset time:

$$t(G) = t_{Drop-off} \text{ when } G < 0.95 * G_S$$

where

$t_{Drop-off}$ (seconds) drop-off time if $G < 0.95 * G_S$, fix, value.

The time delay of the IEEE standard dependent time characteristic is

- "IEEE square law"

$$t = \frac{0.18 * TMS}{\left(\frac{V/f}{V_N/f_N} - \frac{V_{set}/f_{set}}{V_N/f_N}\right)^2} = \frac{0.18 * TMS}{(G - G_S)^2}$$

where

$TMS = 1 \dots 60$
 V/f

V_N/f_N
 V_{set}/f_{set}

time multiplier setting,
flux value calculated at the measured voltage and frequency,
flux at rated voltage and rated frequency,
flux setting value.

The maximum delay time is limited by the parameter *Max Time Delay*. This time delay is valid if the flux is below the preset value *Start U/f LowSet*.

This inverse type characteristic is also combined with a minimum time delay, the value of which is set by user parameter *Min. Time Delay*. This time delay is valid if the flux is above the setting value *Start U/f HighSet*.

The reset time:

If the calculated flux is below the drop-off flux value (when $G < 0.95 * G_s$), then the calculated flux value decreases linearly to zero. The time to reach zero is defined by the parameter *Cooling Time*.

Overexcitation is a typically symmetrical phenomenon. There are other dedicated protection functions against asymmetry. Accordingly, the processing of a single voltage is sufficient. In a network with isolated start point, the phase voltage is not exactly defined due to the uncertain zero sequence voltage component. Therefore, line-to-line voltages are calculated based on the measured phase voltages, and one of them is assigned to overfluxing protection.

The effective frequency range includes all frequencies where the defined accuracy can be achieved. If the frequency is too small, then the time needed to find the peak values and to calculate the flux increases. In contrast, at high frequencies the accuracy of the detected peak value decreases. The frequency range monitored extends from 10 Hz to 70 Hz. The details are given among the technical data.

Similarly to the frequency range, the voltage range is also limited. If the voltage is too small, the voltage measurement becomes inaccurate due to the sampling. In case of high voltage at low frequencies the voltage transformers may also saturate. Accordingly, the frequency range and the voltage range are closely related. The voltage range monitored extends from 10 V to 170 V. The details are given among the technical data.

The flux range is the combination of the voltage range and the frequency range. For overfluxing protection, the effective flux range extends from 0.5 to 1.5 U_N/f_N .

Technical data

Function	Effective range	Accuracy
Voltage measurement	0,5 ... 1,2 U_N	< 1%
Frequency measurement	0,8 ... 1,2 f_N	< 1%

Table 3-1 Technical data of the overexcitation protection function

Parameters

Enumerated parameter

Parameter name	Title	Selection range	Default
Parameter for type selection			
VPH24_Oper_EPar_	Operation	Off, Definite Time, IEEE	Definite Time

Table 3-2 The enumerated parameter of the overexcitation protection function

Integer parameters

Parameter name	Title	Unit	Min	Max	Step	Default
Starting value of the overexcitation protection function						
VPH24_EmaxCont_IPar_	Start U/f LowSet	%	80	140	1	110
Flux value above which the IEEE inverse type characteristic is replaced by the declared minimum time						
VPH24_Emax_IPar_	Start U/f HighSet	%	80	140	1	110
Time multiplier						
VPH24_k_IPar_	Time Multiplier		1	100	1	10

Table 3-3 Integer parameter of the overexcitation protection function

Float parameter

Parameter name	Title	Unit	Min	Max	Step	Default
Minimum time delay for the inverse characteristics and delay for the definite time characteristics:						
VPH24_MinDel_FPar_	Min Time Delay	sec	0.5	60.00	0.01	10.00
Maximum time delay for the inverse characteristics:						
VPH24_MaxDel_FPar_	Max Time Delay	sec	300.00	8000.00	0.01	3000.00
Reset time delay for the inverse characteristics:						
VPH24_CoolDel_FPar_	Cooling Time	sec	60.00	8000.00	0.01	1000.00

Table 3-4 Float parameter of the overexcitation protection function

3.1.2 Definite time undervoltage protection function (TUV27)

The definite time undervoltage protection function measures the RMS values of the fundamental Fourier component of three phase voltages.

The Fourier calculation inputs are the sampled values of the three phase voltages (UL1, UL2, UL3), and the outputs are the basic Fourier components of the analyzed voltages (UL1Four, UL2Four, UL3Four). They are not part of the TUV27 function; they belong to the preparatory phase.

The function generates start signals for the phases individually. The general start signal is generated if the voltage is below the preset starting level parameter setting value and above the defined blocking level.

The function generates a trip command only if the definite time delay has expired and the parameter selection requires a trip command as well.

The operation mode can be chosen by the type selection parameter. The function can be disabled, and can be set to "1 out of 3", "2 out of 3", and "All".

The overvoltage protection function has a binary input signal, which serves the purpose of disabling the function. The conditions of disabling are defined by the user, applying the graphic equation editor.

Technical data

Function	Value	Accuracy
Pick-up starting accuracy		< ± 0,5 %
Blocking voltage		< ± 1,5 %
Reset time		
U> → Un	50 ms	
U> → 0	40 ms	
Operate time accuracy		< ± 20 ms
Minimum operate time	50 ms	

Table 3-5 Technical data of the definite time undervoltage protection function

Parameters

Enumerated parameter

Parameter name	Title	Selection range	Default
Parameter for type selection			
TUV27_Oper_EPar_	Operation	Off, 1 out of 3, 2 out of 3, All	1 out of 3

Table 3-6 The enumerated parameter of the definite time undervoltage protection function

Integer parameters

Parameter name	Title	Unit	Min	Max	Step	Default
Starting voltage level setting						
TUV27_StVol_IPar_	Start Voltage	%	30	130	1	52
Blocking voltage level setting						
TUV27_BlkVol_IPar_	Block Voltage	%	0	20	1	10

Table 3-7 The integer parameters of the definite time undervoltage protection function

Boolean parameter

Parameter name	Title	Default
Enabling start signal only:		
TUV27_StOnly_BPar_	Start Signal Only	FALSE

Table 3-8 The boolean parameter of the definite time undervoltage protection function

Timer parameters

Parameter name	Title	Unit	Min	Max	Step	Default
Time delay of the undervoltage protection function.						
TUV27_Delay_TPar_	Time Delay	ms	0	60000	1	100

Table 3-9 The timer parameter of the definite time undervoltage protection function

3.1.3 Negative sequence overcurrent protection function (TOC46)

The negative sequence overcurrent protection function (TOC46) block operates if the negative sequence current is higher than the preset starting value.

In the negative sequence overcurrent protection function, definite-time or inverse-time characteristics are implemented, according to IEC or IEEE standards. The function evaluates a single measured current, which is the RMS value of the fundamental Fourier component of the negative sequence current. The characteristics are harmonized with IEC 60255-151, Edition 1.0, 2009-08.

The definite (independent) time characteristic has a fixed delaying time when the current is above the starting current G_s previously set as a parameter.

The standard dependent time characteristics of the negative sequence overcurrent protection function are as follows.

$$t(G) = TMS \left[\frac{k}{\left(\frac{G}{G_s}\right)^\alpha - 1} + c \right] \text{ when } G > G_s$$

where

$t(G)$ (seconds)

k, c

α

G

G_s

TMS

theoretical operate time with constant value of G ,
constants characterizing the selected curve (in seconds),
constant characterizing the selected curve (no dimension),
measured value of the characteristic quantity, Fourier base harmonic
of the negative sequence current (INFour),
preset starting value of the characteristic quantity,
preset time multiplier (no dimension).

	IEC ref		k_r	c	α
1	A	IEC Inv	0,14	0	0,02
2	B	IEC VeryInv	13,5	0	1
3	C	IEC ExtInv	80	0	2
4		IEC LongInv	120	0	1
5		ANSI Inv	0,0086	0,0185	0,02
6	D	ANSI ModInv	0,0515	0,1140	0,02
7	E	ANSI VeryInv	19,61	0,491	2
8	F	ANSI ExtInv	28,2	0,1217	2
9		ANSI LongInv	0,086	0,185	0,02
10		ANSI LongVeryInv	28,55	0,712	2
11		ANSI LongExtInv	64,07	0,250	2

Table 3-10 The constants of the standard dependent time characteristics

A parameter (Operation) serves for choosing overcurrent function of independent time delay or dependent one with type selection above.

Time multiplier of the inverse characteristics (TMS) is also a parameter to be preset.

The end of the effective range of the dependent time characteristics (G_D) is:

$$G_D = 20 * G_s$$

Above this value the theoretical operating time is definite. The inverse type characteristics are also combined with a minimum time delay, the value of which is set by user parameter TOC46_MinDel_TPar_ (Min. Time Delay).

The negative phase sequence components calculation is based on the Fourier components of the phase currents.

The binary output status signals of the negative sequence overcurrent protection function are the general starting and the general trip command of the function.

The negative sequence overcurrent protection function has a binary input signal, which serves the purpose of disabling the function. The conditions of disabling are defined by the user, applying the graphic equation editor.

Technical data

Function	Value	Accuracy
Operating accuracy	$10 \leq G_s [\%] \leq 200$	< 2 %
Operate time accuracy		$\pm 5\%$ or ± 15 ms, whichever is greater
Reset ratio	0,95	
Reset time * Dependent time charact. Definite time charact.	approx. 60 ms	<2 % or ± 35 ms, whichever is greater
Transient overreach		< 2 %
Pickup time at $2 \cdot G_s$	<40 ms	
Overshot time Dependent time charact. Definite time charact.	25 ms 45 ms	
Influence of time varying value of the input current (IEC 60255-151)		< 4 %

* Measured with signal contacts

Table 3-11 Technical data of the negative sequence overcurrent protection function

Parameters

Enumerated parameter

Parameter name	Title	Selection range	Default
Parameter for type selection			
TOC46_Oper_EPar_	Operation	Off, DefinitTime, IEC Inv, IEC VeryInv, IEC ExtInv, IEC LongInv, ANSI Inv, ANSI ModInv, ANSI VeryInv, ANSI ExtInv, ANSI LongInv, ANSI LongVeryInv, ANSI LongExtInv	Definit Time

Table 3-12 The enumerated parameter of the negative sequence overcurrent protection function

Integer parameter

Parameter name	Title	Unit	Min	Max	Step	Default
Starting current parameter:						
TOC46_StCurr_IPar_	Start Current	%	5	200	1	50

Table 3-13 The integer parameter of the negative sequence overcurrent protection function

Float point parameter

Parameter name	Title	Unit	Min	Max	Step	Default
Time multiplier of the inverse characteristics (OC module)						
TOC46_Multip_FPar_	Time Multiplier		0.05	999	0.01	1.0

*Valid for inverse type characteristics

Table 3-14 The float point parameter of the time overcurrent protection function

Timer parameters

Parameter name	Title	Unit	Min	Max	Step	Default
Minimal time delay for the inverse characteristics:						
TOC46_MinDel_TPar_	Min Time Delay*	msec	0	60000	1	100
Definite time delay:						
TOC46_DefDel_TPar_	Definite Time Delay**	msec	0	60000	1	100
Reset time delay for the inverse characteristics:						
TOC46_Reset_TPar_	Reset Time*	msec	0	60000	1	100

*Valid for inverse type characteristics

**Valid for definite type characteristics only

Table 3-15 The timer parameter of the negative sequence overcurrent protection function

3.1.4 Negative sequence definite time overvoltage protection function (TOV47)

The definite time negative sequence overvoltage protection function measures three voltages and calculates the negative sequence component. If the negative sequence component is above the level defined by parameter setting, then a start signal is generated.

The function generates a start signal. The general start signal is generated if the negative sequence voltage component is above the level defined by parameter setting value.

The function generates a trip command only if the time delay has expired and the parameter selection requires a trip command as well.

The function can be disabled by parameter setting or by an external signal, edited by the graphic logic editor.

$$t(G) = t_{OP} \text{ when } G > G_s$$

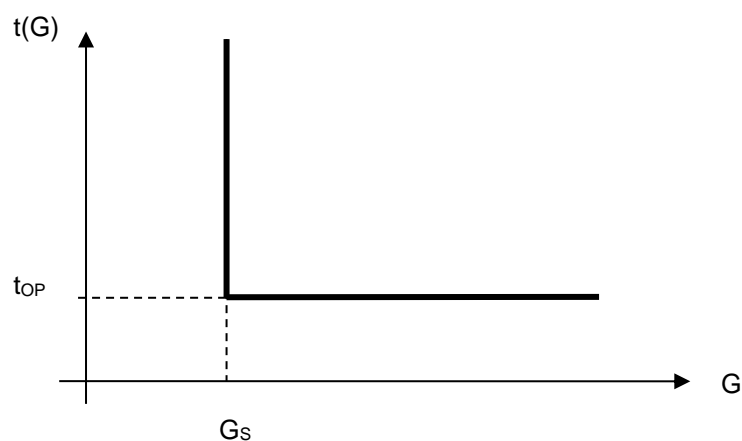

Figure 3-1 Negative sequence overvoltage definite time characteristic

where	
t_{OP} (seconds)	theoretical operating time if $G > G_s$, fix, according to the parameter setting,
G	measured value of the characteristic quantity, Fourier base harmonic of the negative sequence voltage component,
G_s	setting value of the characteristic quantity.

Parameters

Integer parameter

Parameter name	Title	Unit	Min	Max	Step	Default
Voltage level setting. If the voltage is above the setting value, the function generates a start signal.						
TOV47_StVol_IPar__	Start Voltage	%	2	40	1	30

Table 3-16 Integer parameters of the negative sequence overvoltage protection function

Timer parameter

Parameter name	Title	Unit	Min	Max	Step	Default
Time delay of the overvoltage protection function.						
TOV47_Delay_TPar_	Time Delay	ms	50	60000	1	100

Table 3-17 The timer parameter of the negative sequence overvoltage protection function

The internal **binary output status signals** of the three-phase definite time overvoltage protection function are listed in Table 3-18 below.

Binary output signals	Signal title	Explanation
Start	Start	Starting of the function
Trip	Trip	Trip command of the function

Table 3-18 The internal binary output status signals of the negative sequence definite time overvoltage protection function

Boolean parameter

Parameter name	Title	Default
Enabling start signal only:		
TOV47_StOnly_BPar_	Start Signal Only	FALSE

Table 3-19 The Boolean parameter of the negative sequence definite time overvoltage protection function

The negative sequence overvoltage protection function has a binary input signal, which serves the purpose of disabling the function. **The conditions of disabling are defined by the user, applying the graphic equation editor.**

Technical summary

Function	Value	Accuracy
Pick-up starting accuracy		< ± 0,5 %
Blocking voltage		< ± 1,5 %
Reset time		
U> → Un	60 ms	
U> → 0	50 ms	
Operate time accuracy		< ± 20 ms
Drop-off ratio		± 0.5 %
Minimum operate time	50 ms	

Table 3-20 Technical data of the negative sequence definite time overvoltage protection function

3.1.5 Line thermal protection function (TTR49L)

Basically, line thermal protection measures the three sampled phase currents. RMS values are calculated and the temperature calculation is based on the highest RMS value of the phase currents.

The temperature calculation is based on the step-by-step solution of the thermal differential equation. This method yields “overtemperature”, meaning the temperature above the ambient temperature. Accordingly, the temperature of the protected object is the sum of the calculated “overtemperature” and the ambient temperature.

If the calculated temperature (calculated “overtemperature”+ambient temperature) is above the threshold values, alarm, trip and restart blocking status signals are generated.

For correct setting, the following values must be measured and set as parameters: rated load current is the continuous current applied for the measurement, rated temperature is the steady state temperature at rated load current, base temperature is the temperature of the environment during the measurement and the time constant is the measured heating/cooling time constant of the exponential temperature function.

When energizing the protection device, the algorithm permits the definition of the starting temperature as the initial value of the calculated temperature. The parameter Startup Term. is the initial temperature above the temperature of the environment as compared to the rated temperature above the temperature of the environment

The ambient temperature can be measured using e.g. a temperature probe generating electric analog signals proportional to the temperature. In the absence of such measurement, the temperature of the environment can be set using the dedicated parameter TTR49L_Amb_IPar_ (Ambient Temperature). The selection between parameter value and direct measurement is made by setting the binary Boolean parameter.

The problem of metal elements (the protected line) exposed to the sun is that they are overheated as compared to the „ambient” temperature even without a heating current; furthermore, they are cooled mostly by the wind and the heat transfer coefficient is highly dependent on the effects of the wind. As the overhead lines are located in different geographical environments along the tens of kilometers of the route, the effects of the sun and the wind cannot be considered in detail. The best approximation is to measure the temperature of a piece of overhead line without current but exposed to the same environmental conditions as the protected line itself.

The application of thermal protection of the overhead line is a better solution than a simple overcurrent-based overload protection because thermal protection “remembers” the preceding load states of the line and the setting of the thermal protection does not need so a high security margin between the permitted current and the permitted continuous thermal current of the line. In a broad range of load states and in a broad range of ambient temperatures this permits the better exploitation of the thermal and consequently current carrying capacity of the line.

The thermal differential equation to be solved is:

$$\frac{d\Theta}{dt} = \frac{1}{T} \left(\frac{I^2(t)R}{hA} - \Theta \right), \text{ and the definition of the heat time constant is: } T = \frac{cm}{hA}$$

In this differential equation:

I(t) (RMS)	heating current, the RMS value usually changes over time;
R	resistance of the line;
c	specific heat capacity of the conductor;
m	mass of the conductor;
θ	rise of the temperature above the temperature of the environment;
h	heat transfer coefficient of the surface of the conductor;
A	area of the surface of the conductor;
t	time.

The solution of the thermal differential equation for constant current is the temperature as the function of time (the mathematical derivation of this equation is described in a separate document):

$$\Theta(t) = \frac{I^2 R}{hA} \left(1 - e^{-\frac{t}{T}} \right) + \Theta_o e^{-\frac{t}{T}}$$

where

Θ_o is the starting temperature.

Remember that the calculation of the measurable temperature is as follows:

$$\text{Temperature}(t) = \Theta(t) + \text{Temp_ambient}$$

where

Temp_ambient is the ambient temperature.

In a separate document it is proven that some more easily measurable parameters can be introduced instead of the aforementioned ones. Thus, the general form of equation above is:

$$H(t) = \frac{\Theta(t)}{\Theta_n} = \frac{I^2}{I_n^2} \left(1 - e^{-\frac{t}{T}} \right) + \frac{\Theta_o}{\Theta_n} e^{-\frac{t}{T}}$$

where:

$H(t)$ is the „thermal level” of the heated object, this is the temperature as a percentage of the Θ_n reference temperature. (This is a dimensionless quantity but it can also be expressed in a percentage form.)

Θ_n is the reference temperature above the temperature of the environment, which can be measured in steady state, in case of a continuous I_n reference current.

I_n is the reference current (can be considered as the nominal current of the heated object). If it flows continuously, then the reference temperature can be measured in steady state.

$\frac{\Theta_o}{\Theta_n}$ is a parameter of the starting temperature related to the reference temperature

The *RMS calculations modul* calculate the RMS values of the phase currents individually. The sampling frequency of the calculations is 1 kHz; therefore, theoretically, the frequency components below 500Hz are considered correctly in the RMS values. This module is not part of the thermal overload function; it belongs to the preparatory phase.

The *Max selection module* selects the maximal value of the three RMS phase currents.

The *Thermal replica module* solves the first order thermal differential equation using a simple step-by-step method and compares the calculated temperature to the values set by parameters. The temperature sensor value proportional to the ambient temperature can be an input (this signal is optional, defined at parameter setting).

The function can be disabled by parameter, or generates a trip pulse if the calculated temperature exceeds the trip value, or generates a trip signal if the calculated temperature exceeds the trip value given by a parameter but it resets only if the temperature cools below the “Unlock temperature”.

The line thermal protection function has two binary input signals. The conditions of the input signal are defined by the user, applying the graphic equation editor. One of the signals can block the line thermal protection function, the other one can reset the accumulated heat and set the temperature to the defined value for the subsequent heating test procedure.

Technical data

Function	Accuracy
Operate time at $I > 1.2 \cdot I_{trip}$	$< 3\%$ or $< + 20\text{ ms}$

Table 3-21 Technical data of the line thermal protection function

Parameters

Enumerated parameter

Parameter name	Title	Selection range	Default
Parameter for mode of operation			
TTR49L_Oper_EPar_	Operation	Off, Pulsed, Locked	Pulsed

Table 3-22 The enumerated parameter of the line thermal protection function

The meaning of the enumerated values is as follows:

- Off the function is switched off; no output status signals are generated;
- Pulsed the function generates a trip pulse if the calculated temperature exceeds the trip value
- Locked the function generates a trip signal if the calculated temperature exceeds the trip value. It resets only if the temperature cools below the "Unlock temperature".

Integer parameters

Parameter name	Title	Unit	Min	Max	Step	Default
Alarm Temperature						
TTR49L_Alm_IPar_	Alarm Temperature	deg	60	200	1	80
Trip Temperature						
TTR49L_Trip_IPar_	Trip Temperature	deg	60	200	1	100
Rated Temperature						
TTR49L_Max_IPar_	Rated Temperature	deg	60	200	1	100
Base Temperature						
TTR49L_Ref_IPar_	Base Temperature	deg	0	40	1	25
Unlock Temperature						
TTR49L_Unl_IPar_	Unlock Temperature	deg	20	200	1	60
Ambient Temperature						
TTR49L_Amb_IPar_	Ambient Temperature	deg	0	40	1	25
Startup Term.						
TTR49L_Str_IPar_	Startup Term	%	0	60	1	0
Rated Load Current						
TTR49L_Inom_IPar_	Rated Load Current	%	20	150	1	100
Time constant						
TTR49L_pT_IPar_	Time Constant	min	1	999	1	10

Table 3-23 The integer parameters of the line thermal protection function

Boolean parameter

Boolean parameter	Signal title	Selection range	Default
Parameter for ambient temperature sensor application			
TTR49L_Sens_BPar_	Temperature Sensor	No, Yes	No

Table 3-24 The boolean parameter of the line thermal protection function

3.1.6 Three-phase instantaneous overcurrent protection function (IOC50)

The three-phase instantaneous overcurrent protection function (IOC50) operates immediately if the phase currents are higher than the setting value.

The setting value is a parameter, and it can be doubled by graphic programming of the dedicated input binary signal defined by the user.

The function is based on peak value selection or on the RMS values of the Fourier basic harmonic calculation, according to the parameter setting. The fundamental Fourier components are results of an external function block.

Parameter for type selection has selection range of Off, Peak value and Fundamental value. When Fourier calculation is selected then the accuracy of the operation is high, the operation time however is above one period of the network frequency. If the operation is based on peak values then fast sub-cycle operation can be expected, but the transient overreach can be high.

The function generates trip commands without additional time delay if the detected values are above the current setting value. The function generates trip commands for the three phases individually and a general trip command as well.

The instantaneous overcurrent protection function has a binary input signal, which serves the purpose of disabling the function. The conditions of disabling are defined by the user, applying the graphic equation editor.

Technical data

Function

	Using peak value calculation	Accuracy
Operating characteristic	Instantaneous	<6%
Reset ratio	0.85	
Operate time at 2*Is	<15 ms	
Reset time *	< 40 ms	
Transient overreach	90 %	
Using Fourier basic harmonic calculation		
Operating characteristic	Instantaneous	<2%
Reset ratio	0.85	
Operate time at 2* Is	<25 ms	
Reset time *	< 60 ms	
Transient overreach	15 %	

*Measured with signal contacts

Table 3-25 Technical data of the instantaneous overcurrent protection function

Parameters

Enumerated parameter

Parameter name	Title	Selection range	Default
Parameter for type selection			
IOC50_Oper_EPar_	Operation	Off, Peak value, Fundamental value	Peak value

Table 3-26 The enumerated parameter of the instantaneous overcurrent protection function

Integer parameter

Parameter name	Title	Unit	Min	Max	Step	Default
Starting current parameter:						
IOC50_StCurr_IPar_	Start Current	%	20	3000	1	200

Table 3-27 The integer parameter of the instantaneous overcurrent protection function

3.1.7 Residual instantaneous overcurrent protection function (IOC50N)

The residual instantaneous overcurrent protection function (IOC50N) block operates immediately if the residual current ($3I_0$) is above the setting value. The setting value is a parameter, and it can be doubled by a dedicated binary input signal defined by the user applying the graphic programming.

The function is based on peak value selection or on the RMS values of the Fourier basic harmonic component of the residual current, according to the parameter setting. The fundamental Fourier component calculation is not part of the IOC50N function.

Parameter for type selection has selection range of Off, Peak value and Fundamental value.

The function generates a trip commands without additional time delay if the detected values are above the current setting value.

The residual instantaneous overcurrent protection function has a binary input signal, which serves the purpose of disabling the function. The conditions of disabling are defined by the user, applying the graphic equation editor.

Technical data

Function		Accuracy
Using peak value calculation		
Operating characteristic ($I > 0.1 I_n$)	Instantaneous	<6%
Reset ratio	0.85	
Operate time at $2 \cdot I_s$	<15 ms	
Reset time *	< 35 ms	
Transient overreach	85 %	
Using Fourier basic harmonic calculation		
Operating characteristic ($I > 0.1 I_n$)	Instantaneous	<3%
Reset ratio	0.85	
Operate time at $2 \cdot I_s$	<25 ms	
Reset time *	< 60 ms	
Transient overreach	15 %	

*Measured with signal contacts

Table 3-28 Technical data of the residual instantaneous overcurrent protection function

Parameters

Enumerated parameter

Parameter name	Title	Selection range	Default
Parameter for type selection			
IOC50N_Oper_EPar_	Operation	Off, Peak value, Fundamental value	Peak value

Table 3-29 The enumerated parameter of the residual instantaneous overcurrent protection function

Integer parameter

Parameter name	Title	Unit	Min	Max	Step	Default
Starting current parameter:						
IOC50N_StCurr_IPar_	Start Current	%	10	400	1	200

Table 3-30 The integer parameter of the residual instantaneous overcurrent protection function

3.1.8 Breaker failure protection function (BRF50)

After a protection function generates a trip command, it is expected that the circuit breaker opens and the fault current drops below the pre-defined normal level.

If not, then an additional trip command must be generated for all backup circuit breakers to clear the fault. At the same time, if required, a repeated trip command can be generated to the circuit breakers which are a priori expected to open.

The breaker failure protection function can be applied to perform this task.

The starting signal of the breaker failure protection function is usually the trip command of any other protection function assigned to the protected object. The user has the task to define these starting signals using the graphic equation editor, or if the operation of the individual phases is needed, then the start signals for the phases individually.

Two dedicated timers start at the rising edge of the start signals at the same time, one for the backup trip command and one for the repeated trip command, separately for operation in the individual phases. During the running time of the timers the function optionally monitors the currents, the closed state of the circuit breakers or both, according to the user's choice. The selection is made using an enumerated parameter.

If current supervision is selected by the user then the current limit values must be set correctly. The binary inputs indicating the status of the circuit breaker poles have no meaning.

If contact supervision is selected by the user then the current limit values have no meaning. The binary inputs indicating the status of the circuit breaker poles must be programmed correctly using the graphic equation editor.

If the parameter selection is "Current/Contact", the current parameters and the status signals must be set correctly. The breaker failure protection function resets only if all conditions for faultless state are fulfilled.

If at the end of the running time of the backup timer the currents do not drop below the pre-defined level, and/or the monitored circuit breaker is still in closed position, then a backup trip command is generated.

If repeated trip command is to be generated for the circuit breakers that are expected to open, then the enumerated parameter Retrip must be set to "On". In this case, at the end of the retrip timer(s) a repeated trip command is also generated in the phase(s) where the retrip timer(s) run off.

The pulse duration of the trip command is not shorter than the time defined by setting the parameter Pulse length.

The breaker failure protection function can be disabled by setting the enabling parameter to "Off".

Dynamic blocking (inhibition) is possible using the binary input Block. The conditions are to be programmed by the user, using the graphic equation editor.

Technical data

Function	Effective range	Accuracy
Current accuracy		<2 %
Retrip time	approx. 15 ms	
BF time accuracy		± 5 ms
Current reset time	20 ms	

Table 3-31 Technical data of the breaker failure protection function

Parameters

Enumerated parameters

Parameter name	Title	Selection range	Default
Selection of the operating mode			
BRF50_Oper_EPar_	Operation	Off, Current, Contact, Current/Contact	Current
Switching on or off of the repeated trip command			
BRF50_ReTr_EPar_	Retrip	Off, On	On

Table 3-32 The enumerated parameters of the breaker failure protection function

Integer parameters

Parameter name	Title	Unit	Min	Max	Step	Default
Phase current setting						
BRF50_StCurrPh_IPar_	Start Ph Current	%	20	200	1	30
Neutral current setting						
BRF50_StCurrN_IPar_	Start Res Current	%	10	200	1	20

Table 3-33 The integer parameters of the breaker failure protection function

Timer parameters

Parameter name	Title	Unit	Min	Max	Step	Default
Time delay for repeated trip command generation						
BRF50_TrDel_TPar_	Retrip Time Delay	msec	0	10000	1	200
Time delay for trip command generation for the backup circuit breaker(s)						
BRF50_BUdel_TPar_	Backup Time Delay	msec	60	10000	1	300
Trip command impulse duration						
BRF50_Pulse_TPar_	Pulse Duration	msec	0	60000	1	100

Table 3-34 The timer parameters of the breaker failure protection function

3.1.9 Three-phase time overcurrent protection function (TOC51)

The overcurrent protection function realizes definite time or inverse time characteristics according to IEC or IEEE standards, based on three phase currents. The characteristics are harmonized with IEC 60255-151, Edition 1.0, 2009-08. This function can be applied as main protection for medium-voltage applications or backup or overload protection for high-voltage network elements.

The definite (independent) time characteristic has a fixed time delay when the current is above the starting current I_s previously set as a parameter.

The standard operating characteristics of the inverse time overcurrent protection function are defined by the following formula:

$$t(G) = TMS \left[\frac{k}{\left(\frac{G}{G_s}\right)^\alpha - 1} + c \right] \text{ when } G > G_s$$

where

$t(G)$ (seconds)

k, c

α

G

G_s

TMS

theoretical operate time with constant value of G ,
constants characterizing the selected curve (in seconds),
constants characterizing the selected curve (no dimension),
measured value of the characteristic quantity, Fourier base harmonic
of the phase currents (IL1Four, IL2Four, IL3Four),
preset value of the characteristic quantity (Start current),
preset time multiplier (no dimension).

	IEC ref	Title	k_r	c	α
1	A	IEC Inv	0,14	0	0,02
2	B	IEC VeryInv	13,5	0	1
3	C	IEC ExtInv	80	0	2
4		IEC LongInv	120	0	1
5		ANSI Inv	0,0086	0,0185	0,02
6	D	ANSI ModInv	0,0515	0,1140	0,02
7	E	ANSI VeryInv	19,61	0,491	2
8	F	ANSI ExtInv	28,2	0,1217	2
9		ANSI LongInv	0,086	0,185	0,02
10		ANSI LongVeryInv	28,55	0,712	2
11		ANSI LongExtInv	64,07	0,250	2

The end of the effective range of the dependent time characteristics (G_D) is:

$$G_D = 20 * G_s$$

Above this value the theoretical operating time is definite:

$$t(G) = TMS \left[\frac{k}{\left(\frac{G_D}{G_s}\right)^\alpha - 1} + c \right] \text{ when } G > G_D = 20 * G_s$$

Additionally a minimum time delay can be defined by a dedicated parameter. This delay is valid if it is longer than $t(G)$, defined by the formula above.

Resetting characteristics:

- for IEC type characteristics the resetting is after a fix time delay defined by TOC51_Reset_TPar_ (Reset delay),
- for ANSI types however according to the formula below:

$$t_r(G) = TMS \left[\frac{k_r}{1 - \left(\frac{G}{G_s}\right)^\alpha} \right] \text{ when } G < G_s$$

where

$t_r(G)$ (seconds)

k_r

α

G

G_s

TMS

theoretical reset time with constant value of G ,
 constants characterizing the selected curve (in seconds),
 constants characterizing the selected curve (no dimension),
 measured value of the characteristic quantity, Fourier base harmonic
 of the phase currents,
 preset value of the characteristic quantity (Start current),
 preset time multiplier (no dimension).

	IEC ref	Title	k_r	α
1	A	IEC Inv	Resetting after fix time delay, according to preset parameter TOC51_Reset_TPar_ "Reset delay"	
2	B	IEC VeryInv		
3	C	IEC ExtInv		
4		IEC LongInv		
5		ANSI Inv	0,46	2
6	D	ANSI ModInv	4,85	2
7	E	ANSI VeryInv	21,6	2
8	F	ANSI ExtInv	29,1	2
9		ANSI LongInv	4,6	2
10		ANSI LongVeryInv	13,46	2
11		ANSI LongExtInv	30	2

The binary output status signals of the three-phase overcurrent protection function are starting signals of the three phases individually, a general starting signal and a general trip command.

The overcurrent protection function has a binary input signal, which serves the purpose of disabling the function. The conditions of disabling are defined by the user, applying the graphic equation editor.

Technical data

Function	Value	Accuracy
Operating accuracy	$20 \leq G_s \leq 1000$	< 2 %
Operate time accuracy		$\pm 5\%$ or ± 15 ms, whichever is greater
Reset ratio	0,95	
Reset time * Dependent time char. Definite time char.	Approx 60 ms	< 2% or ± 35 ms, whichever is greater
Transient overreach		< 2 %
Pickup time *	< 40 ms	
Overshot time Dependent time char. Definite time char.	30 ms 50 ms	
Influence of time varying value of the input current (IEC 60255-151)		< 4 %

* Measured with signal relay contact

Table 3-35 Technical data of of the instantaneous overcurrent protection function

Parameters

Enumerated parameters

Parameter name	Title	Selection range	Default
Parameter for type selection			
TOC51_Oper_EPar_	Operation	Off, DefinitTime, IEC Inv, IEC VeryInv, IEC ExtInv, IEC LongInv, ANSI Inv, ANSI ModInv, ANSI VeryInv, ANSI ExtInv, ANSI LongInv, ANSI LongVeryInv, ANSI LongExtInv	Definit Time

Table 3-36 The enumerated parameters of the time overcurrent protection function

Integer parameter

Parameter name	Title	Unit	Min	Max	Step	Default
Starting current parameter:						
TOC51_StCurr_IPar_	Start Current	%	20	1000	1	200

Table 3-37 The integer parameter of the time overcurrent protection function

Float point parameter

Parameter name	Title	Unit	Min	Max	Step	Default
Time multiplier of the inverse characteristics (OC module)						
TOC51_Multip_FPar_	Time Multiplier	sec	0.05	999	0.01	1.0

Table 3-38 The float point parameter of the time overcurrent protection function

Timer parameters

Parameter name	Title	Unit	Min	Max	Step	Default
Minimal time delay for the inverse characteristics:						
TOC51_MinDel_TPar_	Min Time Delay *	msec	0	60000	1	100
Definite time delay:						
TOC51_DefDel_TPar_	Definite Time Delay **	msec	0	60000	1	100
Reset time delay for the inverse characteristics:						
TOC51_Reset_TPar_	Reset Time*	msec	0	60000	1	100

*Valid for inverse type characteristics

**Valid for definite type characteristics only

Table 3-39 The timer parameters of the time overcurrent protection function

3.1.10 Residual overcurrent protection function (TOC51N)

The residual delayed overcurrent protection function can realize definite time or inverse time characteristics according to IEC or IEEE standards, based on the RMS value of the fundamental Fourier component of a single measured current, which can be the measured residual current at the neutral point (3I₀) or the calculated zero sequence current component. The characteristics are harmonized with IEC 60255-151, Edition 1.0, 2009-08.

The definite (independent) time characteristic has a fixed time delay when the current is above the starting current I_s previously set as a parameter.

The standard operating characteristics of the inverse time overcurrent protection function are defined by the following formula:

$$t(G) = TMS \left[\frac{k}{\left(\frac{G}{G_s}\right)^\alpha - 1} + c \right] \text{ when } G > G_s$$

where

t(G)(seconds)

k, c

α

G

G_s

TMS

theoretical operate time with constant value of G,
constants characterizing the selected curve (in seconds),
constant characterizing the selected curve (no dimension),
measured value of the characteristic quantity, Fourier base harmonic
of the residual current (INFour),
preset value of the characteristic quantity (Start current),
preset time multiplier (no dimension).

	IEC ref		k _r	c	α
1	A	IEC Inv	0,14	0	0,02
2	B	IEC VeryInv	13,5	0	1
3	C	IEC ExtInv	80	0	2
4		IEC LongInv	120	0	1
5		ANSI Inv	0,0086	0,0185	0,02
6	D	ANSI ModInv	0,0515	0,1140	0,02
7	E	ANSI VeryInv	19,61	0,491	2
8	F	ANSI ExtInv	28,2	0,1217	2
9		ANSI LongInv	0,086	0,185	0,02
10		ANSI LongVeryInv	28,55	0,712	2
11		ANSI LongExtInv	64,07	0,250	2

The end of the effective range of the dependent time characteristics (G_D) is:

$$G_D = 20 * G_s$$

Above this value the theoretical operating time is definite:

$$t(G) = TMS \left[\frac{k}{\left(\frac{G_D}{G_s}\right)^\alpha - 1} + c \right] \text{ when } G > G_D = 20 * G_s$$

Additionally a minimum time delay can be defined by a dedicated parameter (Min. Time Delay). This delay is valid if it is longer than t(G), defined by the formula above.

Resetting characteristics:

- for IEC type characteristics the resetting is after a fix time delay,
- for ANSI types however according to the formula below:

$$t_r(G) = TMS \left[\frac{k_r}{1 - \left(\frac{G}{G_s}\right)^\alpha} \right] \text{ when } G < G_s$$

where

$t_r(G)$ (seconds)

k_r

α

G

G_s

TMS

theoretical reset time with constant value of G ,
 constants characterizing the selected curve (in seconds),
 constant characterizing the selected curve (no dimension),
 measured value of the characteristic quantity, Fourier base harmonic
 of the residual current,
 preset value of the characteristic quantity (Start current),
 preset time multiplier (no dimension).

	IEC ref		k_r	α
1	A	IEC Inv	Resetting after fix time delay, according to preset parameter TOC51_Reset_TPar_ "Reset delay"	
2	B	IEC VeryInv		
3	C	IEC ExtInv		
4		IEC LongInv		
5		ANSI Inv	0,46	2
6	D	ANSI ModInv	4,85	2
7	E	ANSI VeryInv	21,6	2
8	F	ANSI ExtInv	29,1	2
9		ANSI LongInv	4,6	2
10		ANSI LongVeryInv	13,46	2
11		ANSI LongExtInv	30	2

The binary output status signals of the residual overcurrent protection function are the general starting signal and the general trip command if the time delay determined by the characteristics expired.

The residual overcurrent protection function has a binary input signal, which serves the purpose of disabling the function. The conditions of disabling are defined by the user, applying the graphic equation editor.

Technical data

Function	Value	Accuracy
Operating accuracy *	$20 \leq G_s \leq 1000$	< 3 %
Operate time accuracy		$\pm 5\%$ or ± 15 ms, whichever is greater
Reset ratio	0,95	
Reset time * Dependent time char. Definite time char.	Approx 60 ms	< 2% or ± 35 ms, whichever is greater
Transient overreach		2 %
Pickup time	≤ 40 ms	
Overshot time Dependent time char. Definite time char.	30 ms 50 ms	
Influence of time varying value of the input current (IEC 60255-151)		< 4 %

* Measured in version $I_n = 200$ mA

Table 3-40 The technical data of the residual overcurrent protection function

Parameters

Enumerated parameters

Parameter name	Title	Selection range	Default
Parameter for type selection			
TOC51N_Oper_EPar_	Operation	Off, DefinitTime, IEC Inv, IEC VeryInv, IEC ExtInv, IEC LongInv, ANSI Inv, ANSI ModInv, ANSI VeryInv, ANSI ExtInv, ANSI LongInv, ANSI LongVeryInv, ANSI LongExtInv	Definite Time

Table 3-41 The enumerated parameters of the residual overcurrent protection function

Integer parameter

Parameter name	Title	Unit	Min	Max	Step	Default
Starting current parameter:						
TOC51N_StCurr_IPar_	Start Current *	%	5	200	1	50
TOC51N_StCurr_IPar_	Start Current **	%	10	1000	1	50

* $I_n = 1 A$ or $5 A$

** $I_n = 200 mA$ or $1 A$

Table 3-42 The integer parameter of the residual overcurrent protection function

Float point parameter

Parameter name	Title	Unit	Min	Max	Step	Default
Time multiplier of the inverse characteristics (OC module)						
TOC51N_Multip_FPar_	Time Multiplier	sec	0.05	999	0.01	1.0

Table 3-43 The float parameter of the residual overcurrent protection function

Timer parameters

Parameter name	Title	Unit	Min	Max	Step	Default
Minimal time delay for the inverse characteristics:						
TOC51N_MinDel_TPar_	Min Time Delay*	msec	0	60000	1	100
Definite time delay:						
TOC51N_DefDel_TPar_	Definite Time Delay**	msec	0	60000	1	100
Reset time delay for the inverse characteristics:						
TOC51N_Reset_TPar_	Reset Time*	msec	0	60000	1	100

*Valid for inverse type characteristics

**Valid for definite type characteristics only

Table 3-44 The timer parameters of the residual overcurrent protection function

3.1.11 Residual definite time overvoltage protection function (TOV59N)

The residual definite time overvoltage protection function operates according to definite time characteristics, using the RMS values of the fundamental Fourier component of the zero sequence voltage ($U_N=3U_0$).

The Fourier calculation inputs are the sampled values of the residual or neutral voltage ($U_N=3U_0$) and the outputs are the RMS value of the basic Fourier components of those.

The function generates start signal if the residual voltage is above the level defined by parameter setting value.

The function generates a trip command only if the definite time delay has expired and the parameter selection requires a trip command as well.

The residual overvoltage protection function has a binary input signal, which serves the purpose of disabling the function. The conditions of disabling are defined by the user, applying the graphic equation editor.

Technical data

Function	Value	Accuracy
Pick-up starting accuracy	2 – 8 % 8 – 60 %	< ± 2 % < ± 1.5 %
Reset time U> → Un U> → 0	60 ms 50 ms	
Operate time	50 ms	< ± 20 ms

Table 3-45 Technical data of the residual definite time overvoltage protection function

Parameters

Enumerated parameter

Parameter name	Title	Selection range	Default
Parameter for enabling/disabling:			
TOV59N_Oper_EPar_	Operation	Off, On	On

Table 3-46 The enumerated parameter of the residual definite time overvoltage protection function

Integer parameter

Parameter name	Title	Unit	Min	Max	Step	Default
Starting voltage parameter:						
TOV59N_StVol_IPar_	Start Voltage	%	2	60	1	30

Table 3-47 The integer parameter of the residual definite time overvoltage protection function

Boolean parameter

Parameter name	Title	Default
Enabling start signal only:		
TOV59N_StOnly_BPar_	Start Signal Only	FALSE

Table 3-48 The boolean parameter of the residual definite time overvoltage protection function

Timer parameter

Parameter name	Title	Unit	Min	Max	Step	Default
Definite time delay:						
TOV59N_Delay_TPar_	Time Delay	ms	0	60000	1	100

Table 3-49 The time parameter of the residual definite time overvoltage protection function

3.1.12 Definite time overvoltage protection function (TOV59)

The definite time overvoltage protection function measures three voltages. The measured values of the characteristic quantity are the RMS values of the basic Fourier components of the phase voltages.

The Fourier calculation inputs are the sampled values of the three phase voltages (UL1, UL2, UL3), and the outputs are the basic Fourier components of the analyzed voltages (UL1Four, UL2Four, UL3Four). They are not part of the TOV59 function; they belong to the preparatory phase.

The function generates start signals for the phases individually. The general start signal is generated if the voltage in any of the three measured voltages is above the level defined by parameter setting value.

The function generates a trip command only if the definite time delay has expired and the parameter selection requires a trip command as well.

The overvoltage protection function has a binary input signal, which serves the purpose of disabling the function. The conditions of disabling are defined by the user, applying the graphic equation editor.

Technical data

Function	Value	Accuracy
Pick-up starting accuracy		< ± 0,5 %
Blocking voltage		< ± 1,5 %
Reset time U< → Un U< → 0	60 ms 50 ms	
Operate time accuracy		< ± 20 ms
Minimum operate time	50 ms	

Table 3-50 Technical data of the definite time overvoltage protection function

Parameters

Enumerated parameter

Parameter name	Title	Selection range	Default
Enabling or disabling the overvoltage protection function			
TOV59_Oper_EPar_	Operation	Off, On	On

Table 3-51 The enumerated parameter of the definite time overvoltage protection function

Integer parameter

Parameter name	Title	Unit	Min	Max	Step	Default
Voltage level setting. If the measured voltage is above the setting value, the function generates a start signal.						
TOV59_StVol_IPar_	Start Voltage	%	30	130	1	63

Table 3-52 The integer parameter of the definite time overvoltage protection function

Boolean parameter

Parameter name	Title	Default
Enabling start signal only:		
TOV59_StOnly_BPar_	Start Signal Only	FALSE

Table 3-53 The boolean parameter of the definite time overvoltage protection function

Timer parameter

Parameter name	Title	Unit	Min	Max	Step	Default
Time delay of the overvoltage protection function.						
TOV59_Delay_TPar_	Time Delay	ms	0	60000	1	100

Table 3-54 The timer parameter of the definite time overvoltage protection function

3.1.13 Inrush detection function (INR68)

When an inductive element with an iron core (transformer, reactor, etc.) is energized, high current peak values can be detected. This is caused by the transient asymmetric saturation of the iron core as a nonlinear element in the power network. The sizing of the iron core is usually sufficient to keep the steady state magnetic flux values below the saturation point of the iron core, so the inrush transient slowly dies out. These current peaks depend also on random factors such as the phase angle at energizing. Depending on the shape of the magnetization curve of the iron core, the detected peaks can be several times above the rated current peaks. Additionally, in medium or high voltage networks, where losses and damping are low, the indicated high current values may be sustained at length. Figure below shows a typical example for the inrush current shapes of a three-phase transformer.

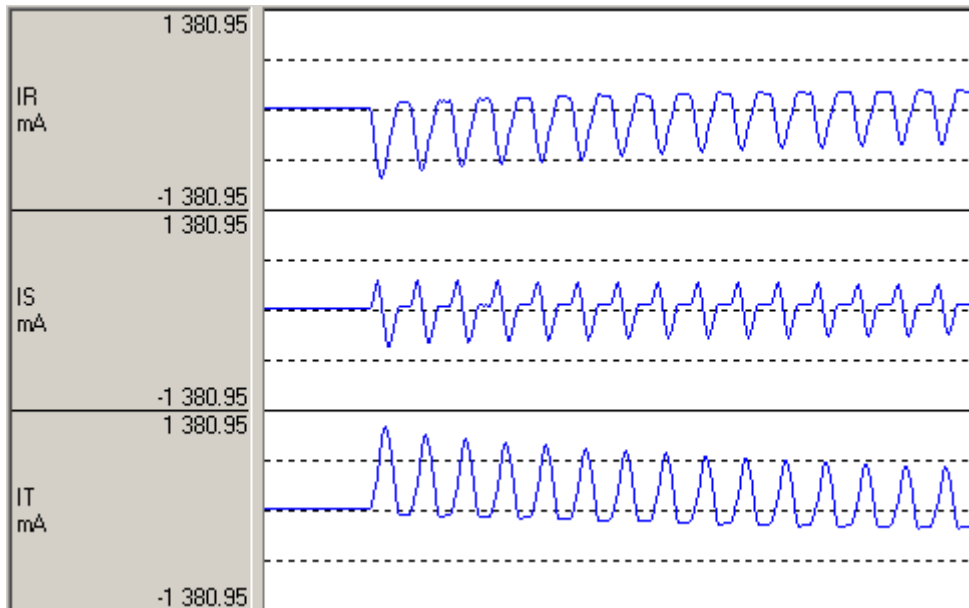

A typical inrush current

As a consequence, overcurrent relays, differential relays or distance relays may start, and because of the long duration of the high current peaks, they may generate an unwanted trip command.

The inrush current detection function can distinguish between high currents caused by overload or faults and the high currents during the inrush time.

The operating principle of the inrush current detection function is based on the special shape of the inrush current.

The typical inrush current in one or two phases is asymmetrical to the time axis. For example, in IT of the Figure above the positive peaks are high while no peaks can be detected in the negative domain.

The theory of the Fourier analysis states that even harmonic components (2nd, 4th etc.) are dominant in waves asymmetrical to the time axis. The component with the highest value is the second one.

Typical overload and fault currents do not contain high even harmonic components.

The inrush current detection function processes the Fourier basic harmonic component and the second harmonic component of the three phase currents. If the ratio of the second harmonic and the base Fourier harmonic is above the setting value of the parameter *2nd Harm Ratio*, an inrush detection signal is generated.

The signal is output only if the base harmonic component is above the level defined by the setting of the parameter *IPh Base Sens*. This prevents unwanted operation in the event that low currents contain relatively high error signals.

The function operates independently using all three phase currents individually, and additionally, a general inrush detection signal is generated if any of the phases detects inrush current.

The function can be disabled by the binary input *Disable*. This signal is the result of logic equations graphically edited by the user.

Using the inrush detection binary signals, other protection functions can be blocked during the transient period so as to avoid the unwanted trip.

Some protection functions use these signals automatically, but a stand-alone inrush detection function block is also available for application at the user's discretion.

Technical data

Function	Range	Accuracy
Current accuracy	20 ... 2000% of In	±1% of In

Table 3-55 Technical data of the inrush detection function

Parameters

Enumerated parameter

Parameter name	Title	Selection range	Default
Disabling or enabling the operation of the function			
INR2_Op_EPar_	Operation	Off,On	On

Table 3-56 The enumerated parameter of the inrush detection function

Integer parameters

Parameter name	Title	Unit	Min	Max	Step	Default
Ratio of the second and basic harmonic Fourier components						
INR2_2HRat_IPar_	2nd Harm Ratio	%	5	50	1	15
Basic sensitivity of the function						
INR2_MinCurr_IPar_	IPh Base Sens	%	20	100	1	30

Table 3-57 The integer parameter of the inrush detection function

3.1.14 Three-phase directional overcurrent protection function (TOC67)

The directional three-phase delayed overcurrent protection function can be applied on solidly grounded networks, where the overcurrent protection must be supplemented with a directional decision.

The inputs of the function are the Fourier basic harmonic components of the three phase currents and those of the three phase voltages and the three line-to-line voltages.

Based on the measured voltages and currents from among the six loops (L1L2, L2L3, L3L1, L1N, L2N, L3N), the function selects the one with the smallest calculated loop impedance. Based on the loop voltage and loop current of the selected loop, the directional decision generates a signal of TRUE value if the voltage and the current is sufficient for directional decision, and the angle difference between the vectors is within the setting range. This decision enables the output start and trip signal of a non-directional three-phase overcurrent protection function block, based on the selected current.

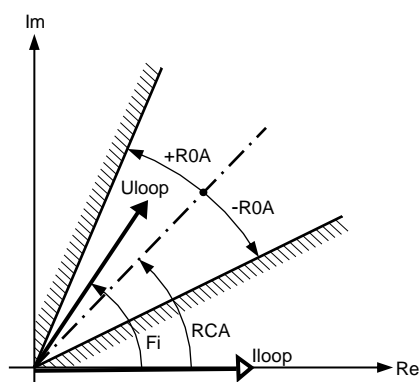

The function can be enabled or disabled by a parameter. The status signal of the VTS (voltage transformer supervision) function can also disable the directional operation.

The voltage must be above 5% of the rated voltage and the current must also be measurable.

If the voltages are below 5% of the rated voltage then the algorithm substitutes the small values with the voltages stored in the memory.

The directional decision module calculates the phase angle between the selected loop voltage and the loop current. The reference signal is the current according to *Figure*.

The three-phase non-directional delayed overcurrent function block (TOC51) is described in a separate document. The additional input binary signal enables the operation of the OC function if the directional decision module generates a logic TRUE value, indicating that the phase angle is in the range defined by the preset parameters or that non-directional operation is set by a parameter.

Technical data

Function	Value	Accuracy
Operating accuracy		< 2 %
Operate time accuracy	If Time multiplier is >0.1	±5% or ±15 ms, whichever is greater
Accuracy in minimum time range		±35 ms
Reset ratio	0,95	
Reset time	Approx 100 ms	
Transient overreach	2 %	
Pickup time	<100 ms	
Memory storage time span		
50 Hz	70 ms	
60 Hz	60 ms	
Angular accuracy		<3°

Table 3-58 Technical data of the three-phase directional overcurrent protection function

Parameters

Enumerated parameters

Parameter name	Title	Selection range	Default
Directionality of the function			
TOC67_Dir_EPar_	Direction	NonDir, Forward, Backward	Forward
Operating characteristic selection of the TOC51 module			
TOC67_Oper_EPar_	Operation	Off, DefiniteTime, IEC Inv, IEC VeryInv, IEC ExtInv, IEC LongInv, ANSI Inv, ANSI ModInv, ANSI VeryInv, ANSI ExtInv, ANSI LongInv, ANSI LongVeryInv, ANSI LongExtInv	DefiniteTime

Table 3-59 The enumerated parameters of the three-phase directional overcurrent protection function

Integer parameters

Parameter name	Title	Unit	Min	Max	Step	Default
Operating angle (see Figure)						
TOC67_ROA_IPar_	Operating Angle	deg	30	80	1	60
Characteristic angle (see Figure)						
TOC67_RCA_IPar_	Characteristic Angle	deg	40	90	1	60
Start current (OC module)						
TOC67_StCurr_IPar_	Start Current	%	20	1000	1	50

Table 3-60 The integer parameters of the three-phase directional overcurrent protection function

Float point parameter

Parameter name	Title	Unit	Min	Max	Digits	Default
Time multiplier of the inverse characteristics (OC module)						
TOC67_Multip_FPar_	Time Multiplier		0.05	999	0.01	1.0

Table 3-61 The float point parameter of the three-phase directional overcurrent protection function

Timer parameters

Parameter name	Title	Unit	Min	Max	Step	Default
Minimal time delay for the inverse characteristics (OC module):						
TOC67_MinDel_TPar_	Min. Time	msec	50	60000	1	100
Definite time delay (OC module):						
TOC67_DefDel_TPar_	Definite Time	msec	0	60000	1	100
Reset time delay for the inverse characteristics (OC module):						
TOC67_Reset_TPar_	Reset Time	msec	0	60000	1	100

Table 3-62 The timer parameters of the three-phase directional overcurrent protection function

3.1.15 Switch-onto-fault preparation function (SOTF)

Some protection functions, e.g. distance protection, directional overcurrent protection, etc. also need to decide the direction of the fault. This decision is based on the angle between the voltage and the current. In case of close-up faults, however, the voltage of the faulty loop is near zero: it is not sufficient for a directional decision. If there are no healthy phases, then the voltage samples stored in the memory are applied to decide if the fault is forward or reverse.

If the protected object is energized, the close command for the circuit breaker is received in “dead” condition. This means that the voltage samples stored in the memory have zero values. In this case the decision on the trip command is based on the programming of the protection function for the “switch-onto-fault” condition.

This “switch-onto-fault” detection function prepares the conditions for the subsequent decision.

The function can handle both automatic and manual close commands.

The automatic close command is not an input for this function. It receives the “Dead line” status signal from the DLD (dead line detection) function block. After dead line detection, the AutoSOTF binary output is delayed by a timer with a constant 200 ms time delay. After voltage detection (resetting of the dead line detection input signal), the drop-off of the output signal is delayed by a timer set by the user.

The manual close command is an input binary signal. The drop-off of this signal is delayed by a timer with timing set by the user.

The fault detection is the task of the subsequent distance protection, directional overcurrent protection, etc.

The operation of the “switch-onto-fault” detection function is shown in Figure 3-2.

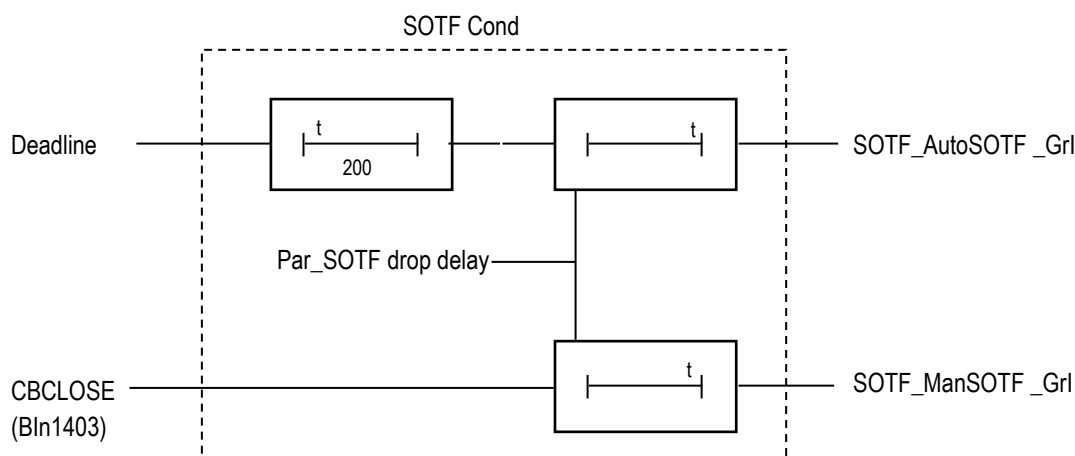

Figure 3-2 The scheme of the “switch-onto-fault” preparation

Technical data

Function	Accuracy
Timer accuracy	±5% or ±15 ms, whichever is greater

Table 3-63 Technical data of the switch-onto-fault detection

Parameters**Timer parameter**

Parameter name	Title	Unit	Min	Max	Step	Default
Drop-off time delay for the signal						
SOTF_SOTFDeI_TPar_	SOTF Drop Delay	msec	100	10000	1	1000

Table 3-64 The timer parameter of the switch-onto-fault detection function

3.1.16 Residual directional overcurrent protection function (TOC67N)

The main application area of the directional residual delayed overcurrent protection function is an earth-fault protection.

The inputs of the function are the RMS value of the Fourier basic harmonic components of the zero sequence current ($I_N=3I_0$) and those of the zero sequence voltage ($U_N=3U_0$).

The block of the directional decision generates a signal of TRUE value if the $U_N=3U_0$ zero sequence voltage and the $I_N=3I_0$ zero sequence current are above the limits needed for correct directional decision, and the angle difference between the vectors is within the preset range. The decision enables the output start and trip signal of an overcurrent protection function block (TOC51N). This non-directional residual overcurrent protection function block is described in a separate document.

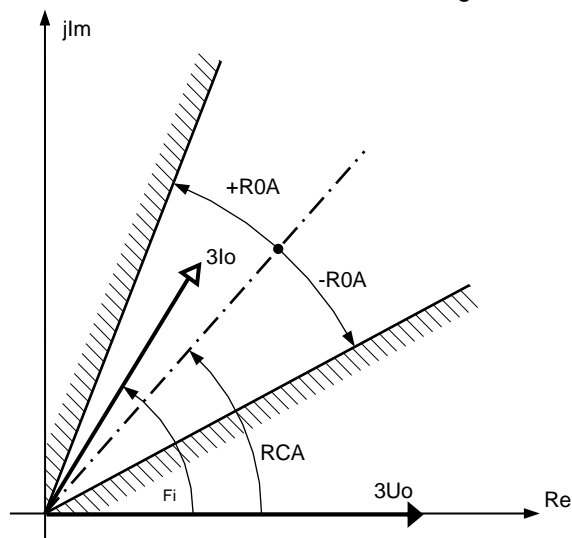

The directional decision module calculates the phase angle between the residual voltage and the residual current. The reference signal is the residual voltage according to the Figure.

The directional decision module calculates the phase angle between the residual voltage and the residual current. The reference signal is the residual voltage according to the Figure.

The output of the directional decision module is OK, namely it is TRUE if the phase angle between the residual voltage and the residual current is within the limit range defined by the preset parameter OR if non-directional operation is selected by the preset parameter (Direction=NonDir).

Technical data

Function	Value	Accuracy
Operating accuracy		< ±2 %
Operate time accuracy		±5% or ±15 ms, whichever is greater
Accuracy in minimum time range		±35 ms
Reset ratio	0,95	
Reset time	Approx 50 ms	±35 ms
Transient overreach	<2 %	
Pickup time	25 – 30 ms	
Angular accuracy		
$I_0 \leq 0.1 I_n$		< ±10°
$0.1 I_n < I_0 \leq 0.4 I_n$		< ±5°
$0.4 I_n < I_0$		< ±2°
Angular reset ratio		
Forward and backward	10°	
All other selection	5°	

Table 3-65 The technical data of the residual directional overcurrent protection function

Parameters

Enumerated parameters

Parameter name	Title	Selection range	Default
Directionality of the function			
TOC67N_Dir_EPar_	Direction	NonDir,Forward-Angle,Backward-Angle,Forward-I*cos(fi),Backward-I*cos(fi),Forward-I*sin(fi),Backward-I*sin(fi),Forward-I*sin(fi+45),Backward-I*sin(fi+45)	Forward-Angle
Operating characteristic selection of the TOC51N module			
TOC67N_Oper_EPar_	Operation	Off,DefiniteTime,IEC Inv,IEC VeryInv,IEC ExtInv,IEC LongInv,ANSI Inv,ANSI ModInv,ANSI VeryInv,ANSI ExtInv,ANSI LongInv,ANSI LongVeryInv,ANSI LongExtInv	DefiniteTime

Table 3-66 The enumerated parameters of the residual directional overcurrent protection function

Short explanation of the enumerated parameter “Direction”

Selected value	Explanation
NonDir,	Operation according to non-directional TOC51N
Forward-Angle	See Figure, set RCA (Characteristic Angle) and ROA (Operating Angle) as required
Backward-Angle	$RCA_{actual} = RCA_{set} + 180^\circ$, set RCA (Characteristic Angle) and ROA (Operating Angle) as required
Forward-I*cos(fi)	$RCA = 0^\circ$ fix, $ROA = 85^\circ$ fix, the setting values RCA and ROA are not applied
Backward-I*cos(fi)	$RCA = 180^\circ$ fix, $ROA = 85^\circ$ fix, the setting values RCA and ROA are not applied
Forward-I*sin(fi)	$RCA = 90^\circ$ fix, $ROA = 85^\circ$ fix, the setting values RCA and ROA are not applied
Backward-I*sin(fi)	$RCA = -90^\circ$ fix, $ROA = 85^\circ$ fix, the setting values RCA and ROA are not applied
Forward-I*sin(fi+45)	$RCA = 45^\circ$ fix, $ROA = 85^\circ$ fix, the setting values RCA and ROA are not applied
Backward-I*sin(fi+45)	$RCA = -135^\circ$ fix, $ROA = 85^\circ$ fix, the setting values RCA and ROA are not applied

Table 3-67 The short explanation of the enumerated parameters of the residual directional overcurrent protection function

Integer parameters

Parameter name	Title	Unit	Min	Max	Step	Default
The threshold value for the 3Uo zero sequence voltage, below which no directionality is possible. % of the rated voltage of the voltage transformer input						
TOC67N_UoMin_IPar_	URes Min	%	1	10	1	2
The threshold value for the 3Io zero sequence current, below which no operation is possible. % of the rated current of the current transformer input						
TOC67N_IoMin_IPar_	IRes Min	%	1	50	1	5
Operating angle (See Figure)						
TOC67N_ROA_IPar_	Operating Angle	deg	30	80	1	60
Characteristic angle (See Figure)						
TOC67N_RCA_IPar_	Characteristic Angle	deg	-180	180	1	60
Start current (TOC51N module)						
TOC67N_StCurr_IPar_	Start Current	%	5	200	1	50

Table 3-68 The integer parameters of the residual directional overcurrent protection function

Float point parameter

Parameter name	Title	Unit	Min	Step	Step	Default
Time multiplier of the inverse characteristics (TOC51N module)						
TOC67N_Multip_FPar_	Time Multiplier		0.05	999	0.01	1.0

Table 3-69 The float point parameter of the residual directional overcurrent protection function

Timer parameters

Parameter name	Title	Unit	Min	Max	Step	Default
Minimal time delay for the inverse characteristics (TOC 51N module):						
TOC67N_MinDel_TPar_	Min Time Delay	msec	50	60000	1	100
Definite time delay (TOC 51N module):						
TOC67N_DefDel_TPar_	Definite Time Delay	msec	0	60000	1	100
Reset time delay for the inverse characteristics (TOC 51N module):						
TOC67N_Reset_TPar_	Reset Time	msec	0	60000	1	100

Table 3-70 The timer parameters of the residual directional overcurrent protection function

3.1.17 Over-frequency protection function (TOF81)

The deviation of the frequency from the rated system frequency indicates unbalance between the generated power and the load demand. If the available generation is large compared to the consumption by the load connected to the power system, then the system frequency is above the rated value. The over-frequency protection function is usually applied to decrease generation to control the system frequency.

Another possible application is the detection of unintended island operation of distributed generation and some consumers. In the island, there is low probability that the power generated is the same as consumption; accordingly, the detection of high frequency can be one of the indication of island operation.

Accurate frequency measurement is also the criterion for the synchro-check and synchro-switch functions.

The accurate frequency measurement is performed by measuring the time period between two rising edges at zero crossing of a voltage signal. For the acceptance of the measured frequency, at least four subsequent identical measurements are needed. Similarly, four invalid measurements are needed to reset the measured frequency to zero. The basic criterion is that the evaluated voltage should be above 30% of the rated voltage value.

The over-frequency protection function generates a start signal if at least five measured frequency values are above the preset level.

Time delay can also be set.

The function can be enabled/disabled by a parameter.

The over-frequency protection function has a binary input signal. The conditions of the input signal are defined by the user, applying the graphic equation editor. The signal can block the under-frequency protection function.

Technical data

Function	Range	Accuracy
Operate range	40 - 70 Hz	30 mHz
Effective range	45 - 55 Hz / 55 - 65 Hz	2 mHz
Operate time		min 140 ms
Time delay	140 – 60000 ms	± 20 ms
Reset ratio		0,99

Table 3-71 Technical data of the over-frequency protection function

Parameters

Enumerated parameter

Parameter name	Title	Selection range	Default
Selection of the operating mode			
TOF81_Oper_EPar_	Operation	Off,On	On

Table 3-72 The enumerated parameter of the over-frequency protection function

Boolean parameter

Parameter name	Title	Default
Enabling start signal only:		
TOF81_StOnly_BPar_	Start Signal Only	FALSE

Table 3-73 The boolean parameter of the over-frequency protection function

Float point parameter

Parameter name	Title	Unit	Min	Max	Step	Default
Setting value of the comparison						
TOF81_St_FPar_	Start Frequency	Hz	40	60	0.01	51

Table 3-74 The float point parameter of the over-frequency protection function

Timer parameter

Parameter name	Title	Unit	Min	Max	Step	Default
Time delay						
TOF81_Del_TPar_	Time Delay	msec	100	60000	1	200

Table 3-75 The timer parameter of the over-frequency protection function

3.1.18 Underfrequency protection function (TUF81)

The deviation of the frequency from the rated system frequency indicates unbalance between the generated power and the load demand. If the available generation is small compared to the consumption by the load connected to the power system, then the system frequency is below the rated value. The under-frequency protection function is usually applied to increase generation or for load shedding to control the system frequency.

Another possible application is the detection of unintended island operation of distributed generation and some consumers. In the island, there is low probability that the power generated is the same as consumption; accordingly, the detection of low frequency can be one of the indications of island operation.

Accurate frequency measurement is also the criterion for the synchro-check and synchro-switch functions.

The accurate frequency measurement is performed by measuring the time period between two rising edges at zero crossing of a voltage signal. For the acceptance of the measured frequency, at least four subsequent identical measurements are needed. Similarly, four invalid measurements are needed to reset the measured frequency to zero. The basic criterion is that the evaluated voltage should be above 30% of the rated voltage value.

The under-frequency protection function generates a start signal if at least five measured frequency values are below the setting value.

Time delay can also be set.

The function can be enabled/disabled by a parameter.

The under-frequency protection function has a binary input signal. The conditions of the input signal are defined by the user, applying the graphic equation editor. The signal can block the under-frequency protection function.

Technical data

Function	Range	Accuracy
Operate range	40 - 70 Hz	30 mHz
Effective range	45 - 55 Hz / 55 - 65 Hz	2 mHz
Operate time		min 140 ms
Time delay	140 – 60000 ms	± 20 ms
Reset ratio		0,99

Table 3-76 Technical data of the under-frequency protection function

Parameters

Enumerated parameter

Parameter name	Title	Selection range	Default
Selection of the operating mode			
TUF81_Oper_EPar_	Operation	Off, On	On

Table 3-77 The enumerated parameter of the under-frequency protection function

Boolean parameter

Parameter name	Title	Default
Enabling start signal only:		
TUF81_StOnly_BPar_	Start Signal Only	FALSE

Table 3-78 The boolean parameter of the under-frequency protection function

Float point parameter

Parameter name	Title	Unit	Min	Max	Digits	Default
Preset value of the comparison						
TUF81_St_FPar_	Start Frequency	Hz	40	60	0.01	49

Table 3-79 The float point parameter of the under-frequency protection function

Timer parameter

Parameter name	Title	Unit	Min	Max	Step	Default
Time delay						
TUF81_Del_TPar_	Time Delay	ms	100	60000	1	200

Table 3-80 The timer parameter of the under-frequency protection function

3.1.19 Rate of change of frequency protection function (FRC81)

The deviation of the frequency from the rated system frequency indicates unbalance between the generated power and the load demand. If the available generation is large compared to the consumption by the load connected to the power system, then the system frequency is above the rated value, and if it is small, the frequency is below the rated value. If the unbalance is large, then the frequency changes rapidly. The rate of change of frequency protection function is usually applied to reset the balance between generation and consumption to control the system frequency.

Another possible application is the detection of unintended island operation of distributed generation and some consumers. In the island, there is low probability that the power generated is the same as consumption; accordingly, the detection of a high rate of change of frequency can be an indication of island operation.

Accurate frequency measurement is also the criterion for the synchro-switch function.

The source for the rate of change of frequency calculation is an accurate frequency measurement.

In some applications, the frequency is measured based on the weighted sum of the phase voltages.

The accurate frequency measurement is performed by measuring the time period between two rising edges at zero crossing of a voltage signal. For the acceptance of the measured frequency, at least four subsequent identical measurements are needed. Similarly, four invalid measurements are needed to reset the measured frequency to zero. The basic criterion is that the evaluated voltage should be above 30% of the rated voltage value.

The rate of change of frequency protection function generates a start signal if the df/dt value is above the setting value. The rate of change of frequency is calculated as the difference of the frequency at the present sampling and at three periods earlier.

Time delay can also be set.

The function can be enabled/disabled by a parameter.

The rate of change of frequency protection function has a binary input signal. The conditions of the input signal are defined by the user, applying the graphic equation editor. The signal can block the rate of change of frequency protection function.

Technical data

Function	Effective range	Accuracy
Operating range	-5 - -0.05 and +0.05 - +5 Hz/sec	
Pick-up accuracy		±20 mHz/sec
Operate time	min 140 ms	
Time delay	140 – 60000 ms	+ 20 ms

Table 3-81 Technical data of the rate of change of frequency protection function

Parameters

Enumerated parameter

Parameter name	Title	Selection range	Default
Selection of the operating mode			
FRC81_Oper_EPar_	Operation	Off,On	On

Table 3-82 The enumerated parameter of the rate of change of frequency protection function

Boolean parameter

Parameter name	Title	Default
Enabling start signal only:		
FRC81_StOnly_BPar_	Start Signal Only	True

Table 3-83 The boolean parameter of the rate of change of frequency protection function

Float point parameter

Parameter name	Title	Unit	Min	Max	Step	Default
Setting value of the comparison						
FRC81_St_FPar_	Start df/dt	Hz/sec	-5	5	0.01	0.5

Table 3-84 The float point parameter of the rate of change of frequency protection function

Timer parameters

Parameter name	Title	Unit	Min	Max	Step	Default
Time delay						
FRC81_Del_TPar_	Time Delay	msec	100	60000	1	200

Table 3-85 The timer parameter of the rate of change of frequency protection function

3.1.20 Directional over-power protection function (DOP32)

The directional over-power protection function can be applied to protect any elements of the electric power system mainly generators if the active and/or reactive power has to be limited.

Technical data

Function	Effective range	Accuracy
P,Q measurement	$I > 5\% I_n$	$< 3\%$

Table 3-86 Technical data of the directional over-power protection function

Parameters

Enumerated parameter

Parameter name	Title	Selection range	Default
Switching on/off of the function			
DOP32_Oper_EPar_	Operation	Off,On	On

Table 3-87 The enumerated parameter of the directional over-power protection function

Boolean parameter

Parameter name	Title	Default
Selection: start signal only or both start signal and trip command		
DOP32_StOnly_BPar_	Start Signal Only	0

Table 3-88 The Boolean parameter of the directional over-power protection function

Integer parameter

Parameter name	Title	Unit	Min	Max	Step	Default
Direction angle						
DOP32_RCA_IPar_	Direction Angle	deg	-179	180	1	0

Table 3-89 Integer parameter of the directional over-power protection function

Float parameter

Parameter name	Title	Unit	Min	Max	Step	Default
Minimum power setting						
DOP32_StPow_FPar_	Start Power	%	1	200	0.1	10

Table 3-90 Float parameter of the directional over-power protection function

Timer parameters

Parameter name	Title	Unit	Min	Max	Step	Default
Definite time delay of the trip command						
DOP32_Delay_TPar_	Time Delay	msec	0	60000	1	100

Table 3-91 Timer parameter of the directional over-power protection function

3.1.21 Directional under-power protection function (DUP32)

The directional under-power protection function can be applied mainly to protect any elements of the electric power system, mainly generators, if the active and/or reactive power has to be limited in respect of the allowed minimum power.

Technical data

Function	Effective range	Accuracy
P,Q measurement	$I > 5\% I_n$	$< 3\%$

Table 3-92 Technical data of the directional under-power protection function

Parameters

Enumerated parameter

Parameter name	Title	Selection range	Default
Switching on/off of the function			
DUP32_Oper_EPar_	Operation	Off, On	On

Table 3-93 The enumerated parameter of the directional under-power protection function

Boolean parameter

Parameter name	Title	Default
Selection: start signal only or both start signal and trip command		
DUP32_StOnly_BPar_	Start Signal Only	0

Table 3-94 The Boolean parameter of the directional under-power protection function

Integer parameter

Parameter name	Title	Unit	Min	Max	Step	Default
Direction angle						
DUP32_RCA_IPar_	Direction Angle	deg	-179	180	1	0

Table 3-95 Integer parameter of the directional under-power protection function

Float parameter

Parameter name	Title	Unit	Min	Max	Step	Default
Minimum power setting						
DUP32_StPow_FPar_	Start Power	%	1	200	0,1	10

Table 3-96 Float parameter of the directional under-power protection function

Timer parameter

Parameter name	Title	Unit	Min	Max	Step	Default
Definite time delay of the trip command						
DUP32_Delay_TPar_	Time Delay	msec	0	60000	1	100

Table 3-97 Timer parameter of the directional under-power protection function

3.1.22 Restricted earth fault protection function (DIF87N)

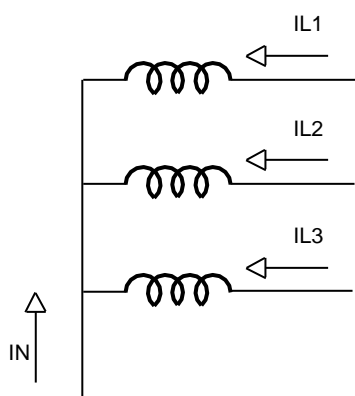

The restricted earth-fault protection function is basically a low-impedance differential protection function based on zero sequence protection components. It can be applied to protect one side winding of transformers with grounded neutral against single-phase-to-earth fault (see Figure). The function compares the measured neutral current at the star point (I_N) and the calculated zero sequence current component of the phase currents (I_{L1} , I_{L2} , I_{L3}) and generates a trip command if the difference of these currents is above the characteristics.

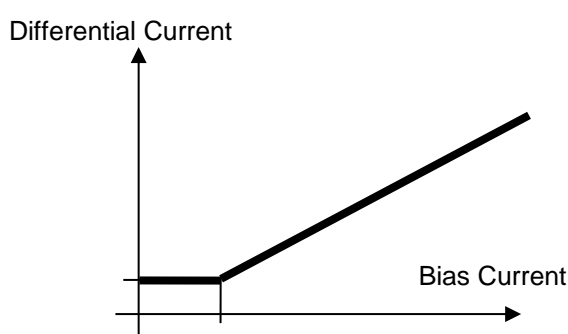

The function performs the necessary calculations for the evaluation of the “percentage differential characteristics”, and decides to trip if the differential current is above the characteristic curve of the zero sequence differential protection function. This curve is the function of the restraint (Bias) current, which is the maximum of the phase currents and the current of the neutral point.

$$\text{Differential Current} = I_{L1Four} + I_{L2Four} + I_{L3Four} + I_{NFour}$$

$$\text{Bias Current} = \text{MAX}(I_{L1Four}, I_{L2Four}, I_{L3Four}, I_{NFour})$$

Note: *Four* = Fourier

Additionally the function compares the direction of the neutral current and that of the calculated zero sequence current. In case of small zero sequence component of the high fault currents in the phases, this decision improves the stability of the function.

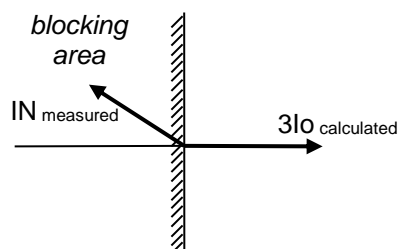

In this system, if the angle between the calculated zero sequence current $3I_0$ and the measured neutral current I_N is out of the range of ± 90 degrees, then the restricted earth fault protection can be blocked (see the Figure). For the directional decision, the positive directions are drawn in Figure above. The output signal of the directional decision module can block the restricted earth-fault protection function.

A Boolean parameter of the restricted earth-fault protection function serves to enable the directional checking of the measured and calculated zero sequence currents.

The restricted earth-fault protection function generates a trip signal if the differential current as the function of the bias current is above the differential characteristic lines and the function is not blocked by the directional decision. Additionally, the operation of the function is enabled by parameter setting. The conditions of enabling are defined by the user applying the graphic equation editor.

Technical data

Function	Value	Accuracy
Operating characteristic	1 breakpoint	
Reset ratio	0,95	
Characteristic accuracy		<2%
Operate time, restrained	typically 20 ms	
Reset time, restrained	typically 25 ms	

Table 3-98 Technical data of the restricted earth fault protection function

Parameters

Enumerated parameter

Parameter name	Title	Selection range	Default
Parameter to enable the zero sequence differential protection function:			
DIF87N_Oper_EPar_	Operation	Off, On	On

Table 3-99 The enumerated parameter of the restricted earth fault protection function

Boolean parameter

Parameter name	Title	Default	Explanation
DIF87N_DirCheck_BPar_	Directional check	True	Enabling the directional checking of the measured and calculated zero sequence currents

Table 3-100 The boolean parameter of the restricted earth fault protection function

Integer parameters

Parameter name	Title	Unit	Min	Max	Step	Default
Parameters for the current magnitude compensation:						
DIF87N_TRPri_IPar_	Io Primary Match	%	20	500	1	100
DIF87N_TRNeut_IPar_	Neutral Match	%	100	1000	1	500
Base sensitivity:						
DIF87N_f1_IPar_	Base Sensitivity	%	10	50	1	30
Slope of the second section of the characteristics:						
DIF87N_f2_IPar_	Slope	%	50	100	1	70
Break point of the characteristic line:						
DIF87N_f2Brk_IPar_	Base Sens Bias Limit	%	100	200	1	125

Table 3-101 The integer parameters of the restricted earth fault protection function

3.1.23 Transformer differential protection function (DIF87_2w)

The differential protection function provides main protection for transformers, generators or large motors, but it can also be applied for overhead lines and cables of solidly grounded networks or for the protection of any combination of the aforementioned objects.

Version DIF87_3w can be applied to protect three-winding transformers. The simpler version DIF87_2w does not process analogue inputs from the tertiary side.

The three-phase power transformers transform the primary current to the secondary side according to the turns ratio and the vector group of the transformers. The Y (star), D (delta) or Z (zig-zag) connection of the three phase coils on the primary and secondary sides causes the vector shift of the currents. The numerical differential protection function applies matrix transformation of the directly measured currents of one side of the transformer to match them with the currents of the other side.

In Protecta's transformer differential protection the target of the matrix transformation is the delta (D) side. Thus the problem of zero sequence current elimination in case of an external ground fault is also solved.

The method of the matrix transformation is defined by the „Code” parameter identifying the transformer vector group connection.

The differential current can be high during the transients of transformer energizing (inrush current) due to the current distortion caused by the transformer iron core asymmetrical saturation. In this case, the second harmonic content of the differential current is applied to disable the false operation of the differential protection function.

The differential current can be high in case of the over-excitation of the transformer due to the current distortion caused by the transformer iron core symmetrical saturation. In this case, the fifth harmonic content of the differential current is applied to disable the false operation of the differential protection function.

The harmonic analysis calculates the basic Fourier components of the three differential currents. These results are needed for the high-speed differential current decision and for the second and fifth harmonic restraint calculation.

The software modules evaluate and compare the result with the parameter values set for the second and fifth harmonic. If the harmonic content relative to the basic harmonic component of the differential currents is high, a restraint signal is generated immediately, and a timer is started at the same time. If the duration of the active status is at least 25 ms, then the resetting of the restraint signal is delayed by an additional 15 ms.

The decision logic module decides if the differential current of the individual phases is above the characteristic curve of the differential protection function. It compares the magnitudes of the differential currents and those of the restraint currents for evaluation of the “percentage differential characteristics”. This curve is the function of the restraint current, which is calculated based on the sum of the magnitude of the phase-shifted phase currents (see Figure below).

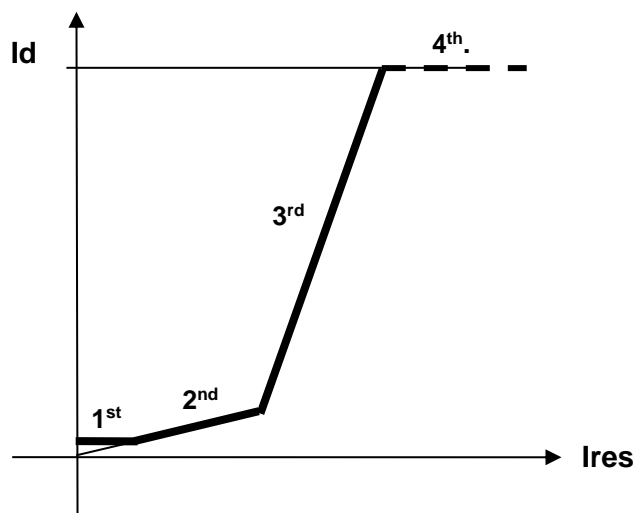

Figure 3-3 Differential characteristics

The characteristic curve has four sections. The first section is the base sensitivity, the second one serves to compensate the turns ratio deviation e.g. due to the operation of the on-load tap changer, the third is to eliminate false operation caused by the CT saturation and the fourth one is the unrestricted differential function. The slope of the third section is constant, it is 2.

The differential protection function has a binary input signal, which serves the purpose of disabling the function. The conditions of disabling are defined by the user applying the graphic equation editor.

Measured values

Measured value	Dim.	Explanation
Idiff. L1	In %	The calculated differential current in phase L1 (after vector group compensation)
Idiff. L2	In %	The calculated differential current in phase L2 (after vector group compensation)
Idiff. L3	In %	The calculated differential current in phase L3 (after vector group compensation)
Ibias L1	In %	The calculated restraint current in phase L1 (after vector group compensation)
Ibias L2	In %	The calculated restraint current in phase L2 (after vector group compensation)
Ibias L3	In %	The calculated restraint current in phase L3 (after vector group compensation)

Remark: The evaluated basic harmonic values of the measured input phase currents (without vector group compensation) help the commissioning of the differential protection function. These evaluations however are performed by an independent software measuring module, so this chapter excludes the description of these measurements.

Table 3-102 The measured values of the differential protection function

Enumerated parameters

Parameter name	Title	Selection range	Default
Parameter to enable the differential protection function:			
DIF87_Op_EPar_	Operation	Off, On	On
Parameter to select connection group of the transformer coils in primary-secondary relation:			
DIF87_VGrSec_EPar_	Pri-Sec VGroup*	Dy1,Dy5,Dy7,Dy11,Dd0,Dd6,Dz0,Dz2,Dz4,Dz6,Dz8,Dz10,Yy0,Yy6,Yd1,Yd5,Yd7,Yd11,Yz1,Yz5,Yz7,Yz11	Dd0
Parameter to select connection group of the transformer coils in primary-tertiary relation:			
DIF87_VGrTer_EPar_	Pri-Ter VGroup*	Dy1,Dy5,Dy7,Dy11,Dd0,Dd6,Dz0,Dz2,Dz4,Dz6,Dz8,Dz10,Yy0,Yy6,Yd1,Yd5,Yd7,Yd11,Yz1,Yz5,Yz7,Yz11	Dd0

* If the connection of the primary winding in primary-secondary and primary tertiary relation is selected in contradiction then the protection function is automatically disabled, and the function generates a warning signal.

Table 3-103 The enumerated parameters of the differential protection function

Boolean parameter

Parameter name	Title	Default	Explanation
DIF87_0Seq_BPar_	Zero Seq Elimination	True	Set this True if there is grounding transformer on the delta side

Table 3-104 The boolean parameter of the differential protection function

Integer parameters

Parameter name	Title	Unit	Min	Max	Step	Default
Parameters for the current magnitude compensation:						
DIF87_TRPr_IPar_	TR Primary Comp	%	20	500	1	100
DIF87_TRSec_IPar_	TR Secondary Comp	%	20	500	1	100
DIF87_TRTer_IPar_	TR Tertiary Comp	%	20	200	1	100
Parameter of the second harmonic restraint:						
DIF87_2HRat_IPar_	2nd Harm Ratio	%	5	50	1	15
Parameter of the fifth harmonic restraint:						
DIF87_5HRat_IPar_	5th Harm Ratio	%	5	50	1	25
Parameters of the percentage characteristic curve:						
Base sensitivity:						
DIF87_f1_IPar_	Base Sensitivity	%	10	50	1	20
Slope of the second section of the characteristics:						
DIF87_f2_IPar_	1st Slope	%	10	50	1	20
Bias limit of the first slope:						
DIF87_f3_IPar_	1st Slope Bias Limit	%	200	2000	1	200
Unrestrained differential protection current level:						
DIF87_HCurr_IPar_	UnRst Diff Current	%	800	2500	1	800

Table 3-105 The integer parameters of the differential protection function

Technical data

Function	Value	Accuracy
Operating characteristic	2 breakpoints	
Reset ratio	0,95	
Characteristic accuracy		<2%
Operate time, unrestrained	Typically 20 ms	
Reset time, unrestrained	Typically 25 ms	
Operate time, restrained	Typically 30 ms	
Reset time, restrained	Typically 25 ms	

Table 3-106 Technical data of the differential protection function

3.1.24 Automatic tap-changer controller function (ATCC)

One criterion for power quality is to keep the voltage of selected points of the networks within the prescribed limits. The most common mode of voltage regulation is the application of transformers with on-load tap changers. When the transformer is connected to different taps, its turns ratio changes and supposing constant primary voltage, the secondary voltage can be increased or decreased as required.

Voltage control can take the actual load state of the transformer and the network into consideration. As a result, the voltage of a defined remote point of the network is controlled assuring that neither consumers near the busbar nor consumers at the far ends of the network get voltages out of the required range.

The voltage control function can be performed automatically or, in manual mode of operation, the personnel of the substation can set the network voltage according to special requirements.

The automatic tap changer controller function can be applied to perform this task.

The automatic tap changer controller function receives the following analog inputs:

UL1L2	Line-to-line voltage of the controlled secondary side of the transformer
IL1L2	Difference of the selected line currents of the secondary side of the transformer for voltage drop compensation
IHV	Maximum of the phase currents of the primary side of the transformer for limitation purposes

The parameter “U Correction” permits fine tuning of the measured voltage.

The function performs the following internal checks before control operation (see Figure below):

- If the voltage of the controlled side UL1L2 is above the value set by the parameter “U High Limit”, then control to increase the voltage is disabled.
- If the voltage of the controlled side UL1L2 is below the value set by the parameter “U Low Limit”, then control to decrease the voltage is disabled.
- If the voltage of the controlled side UL1L2 is below the value set by the parameter “U Low Block”, then the transformer is considered to be de-energized and automatic control is completely disabled.
- If the current of the supply side IHV is above the limit set by the parameter “I Overload”, then both automatic and manual controls are completely disabled. This is to protect the switches inside the tap changer.

Automatic control mode

Voltage compensation in automatic control mode

The function gets the Fourier components of the busbar voltage and those of the current:

- $UL1L2_{Re}$ and $UL1L2_{Im}$
- $IL1L2_{Re}$ and $IL1L2_{Im}$

In automatic control mode the voltage of the controlled side $UL1L2$ is compensated by the current of the controlled side $IL1L2$. This means that the voltage of the “load center” of the network is controlled to be constant, in fact within a narrow range. This assures that neither the voltage near to the busbar is too high, nor the voltage at far-away points of the network is too low. The voltage of the “load center”, i.e. the controlled voltage is calculated as:

$$|U_{control}| = |U_{bus} - U_{drop}|$$

There are two compensation modes to be selected: “AbsoluteComp” and “ComplexComp”.

- If the parameter “Compensation” is set to “**AbsoluteComp**”, the calculation method is as follows:

In this simplified method the vector positions are not considered correctly, the formula above is approximated with the magnitudes only:

$$\begin{aligned} |U_{control}| &= |U_{bus} - U_{drop}| \approx |U_{bus}| - |U_{drop}| \\ &\approx |U_{bus}| - |I| * (R)CompoundFactor \end{aligned}$$

where

(R) Compound Factor is a parameter value.

If the current is above the value defined by the parameter “I Comp Limit”, then in the formulas above this preset value is considered instead of the higher values measured.

The method is based on the experiences of the network operator. Information is needed: how much is the voltage drop between the busbar and the “load center” if the load of the network is the rated load. The parameter “(R) Compound Factor” means in this case the voltage drop in percent.

- If the parameter “Compensation” is set to “**ComplexComp**”, the calculation method is as follows:

In this simplified method the vector positions are partly considered. In the formula above the voltage drop is approximated with the component of the voltage drop, the direction of which is the same as the direction of the bus voltage vector. (This is “length component” of the voltage drop; the “perpendicular component” of the voltage drop is neglected.)

$$\begin{aligned} |U_{control}| &= |U_{bus} \\ &\quad - [IL1L2_{Re} * (R)CompoundFactor - IL1L2_{Im} \\ &\quad * XCompoundFactor]| \end{aligned}$$

where

(R) Compound Factor is a parameter value

X Compound Factor is a parameter value

The voltage of the “load center” of the network is controlled to be within a narrow range. This assures that neither the voltage near to the busbar is too high, nor the voltage at far-away points of the network is too low.

The method is based on the estimated complex impedance between the busbar and the “load center”.

The parameter “*(R) Compound Factor*” means in this case the voltage drop in percent, caused by the real component of the rated current.

The parameter “*X Compound Factor*” means in this case the voltage drop in percent, caused by the imaginary component of the rated current.

NOTE: if the active power flows from the network to the busbar then in “AbsoluteComp” mode no compounding is performed.

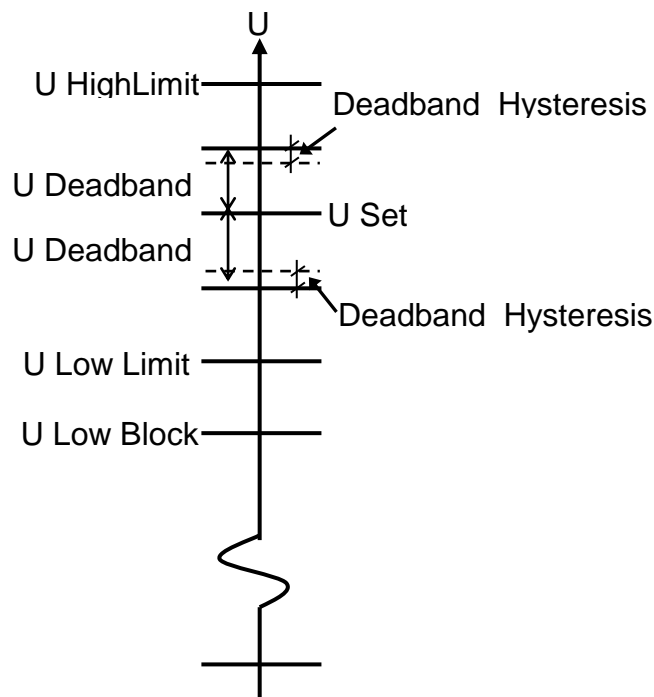

Figure 3-4 Voltage settings for the automatic tap changer function

Voltage checking in automatic control mode

In automatic control mode the calculated $|U_{control}|$ voltage is checked to see if it is outside the limits. The limits are defined by parameter values:

U Set	is the setting value defining the centre of the permitted range
U Deadband	is the width of the permitted range in both + and – directions
Deadband Hysteresis	is the hysteresis decreasing the permitted range of the „U Deadband” after the generation of the control command.

If the calculated $|U_{control}|$ voltage is outside the limits, then timers are started.

In an emergency state of the network, when the network elements are overloaded, the Uset value can be driven to two lower values defined by the parameters “Voltage Reduction 1” and “Voltage Reduction 2”. “U Set” is decreased by the parameter values if the binary inputs “VRed 1” or “VRed 2” enter into active state. These inputs must be programmed graphically by the user.

Time delay in automatic control mode

In automatic control mode the first and every subsequent control command is processed separately.

For the first control command:

The voltage difference is calculated:

$$U_{diff} = |U_{control} - U_{set}|$$

If this difference is above the U Deadband value, and depending on the setting of parameter "T1 Delay Type", three different timing modes can be selected:

- "Definite" this definite time delay is defined by parameter T1
- "Inverse" standard IDMT characteristic defined by the parameters:
 - T1 maximum delay defined by the parameter
 - U Deadband is the width of the permitted range in both + and – directions
 - Min Delay minimum time delay

$$T_{delay} = \frac{T1}{\left(\frac{U_{diff}}{U_{deadband}}\right)}, \text{ but minimum Min Delay}$$

- "2powerN"

$$T_{delay} = T1 * 2^{\left(1 - \frac{U_{diff}}{U_{deadband}}\right)}$$

The binary parameters "Fast Lower Enable" and/or "Fast Higher Enable" enable fast command generation if the voltage is above the parameter value "U High Limit" or below the "U Low Limit". In this case, the time delay is a definite time delay defined by parameter "T2".

For subsequent control commands:

In this case, the time delay is always a definite time delay defined by parameter "T2" if the subsequent command is generated within the „Reclaim time" defined by a parameter.

The automatic control mode can be blocked by a binary signal received via binary input „AutoBlk" and generates a binary output signal "AutoBlocked (ext)"

Manual control mode

In manual mode, the automatic control is blocked. The manual mode can be "Local" or "Remote". For this mode, the input "Manual" needs to be in active state (as programmed by the user).

In the local mode, the input "Local" needs to be in active state. The binary inputs "ManHigher" or "ManLower" must be programmed graphically by the user.

In the remote mode, the input "Remote" needs to be in active state as programmed by the user. In this case manual commands are received via the communication interface.

Command generation and tap changer supervision

The software module "CMD&TC SUPERV" is responsible for the generation of the "HigherCmd" and "LowerCmd" command pulses, the duration of which is defined by the parameter "Pulse Duration". This is valid both for manual and automatic operation.

The tap changer supervision function receives the information about the tap changer position in six bits of the binary inputs "Bit0 to Bit5". The value is decoded according to the enumerated parameter "CodeType", the values of which can be: Binary, BCD or Gray. During switchover, for the transient time defined by the parameter "Position Filter", the position is not evaluated.

The parameters "Min Position" and "Max Position" define the upper and lower limits. In the upper position, no further increasing command is generated and the output "Max Pos Reached" becomes active. Similarly, in the lower position, no further decreasing command is generated and the output "Min Pos Reached" becomes active.

The function also supervises the operation of the tap changer. Depending on the setting of parameter "TC Supervision", three different modes can be selected:

- TCDrive the supervision is based on the input "TCRun". In this case, after command generation the drive is expected to start operation within one quarter of the value defined by the parameter "Max Operating Time" and it is expected to perform the command within "Max Operating Time"
- Position the supervision is based on the tap changer position in six bits of the binary inputs "Bit0 to Bit5". It is checked if the tap position is incremented in case of a voltage increase, or the tap position is decremented in case of a voltage decrease, within the "Max Operating Time".
- Both in this mode the previous two modes are combined.

In case of an error detected in the operation of the tap changer, the "Locked" input becomes active and no further commands are performed. To enable further operation, the input "Reset" must be programmed for an active state by the user.

Technical data

Function	Range	Accuracy
Voltage measurement	$50\% < U < 130\%$	<1%
Definite time delay		<2% or ± 20 ms, whichever is greater
Inverse and "2powerN" time delay	$12\% < U < 25\%$	<5%
	$25\% < U < 50\%$	<2% or ± 20 ms, whichever is greater

Table 3-107 Technical data of the automatic tap changer controller function

Parameters

Enumerated parameters

Parameter name	Title	Selection range	Default
Control model, according to IEC 61850			
ATCC_ctlMod_EPar_	ControlModel	Direct normal, Direct enhanced, SBO enhanced	Direct normal
Select before operate class, according to IEC 61850			
ATCC_sboClass_EPar_	sboClass	Operate-once, Operate-many	Operate-once
Parameter for general blocking of the function			
ATCC_Oper_EPar_	Operation	Off,On	Off
Parameter for time delay mode selection			
ATCC_T1Type_EPar_	T1 Delay Type	Definite, Inverse, 2powerN	Definite
Selection for compensation mode			
ATCC_Comp_EPar_	Compensation	Off, AbsoluteComp, ComplexComp	Off
Tap changed supervision mode selection			
ATCC_TCSuper_EPar_	TC Supervision	Off, TCDrive, Position, Both	Off
Decoding of the position indicator bits			
ATCC_CodeType_EPar_	CodeType	Binary, BCD, Gray	Binary

Table 3-108 The enumerated parameters of the automatic tap changer controller function

Boolean parameters

Parameter name	Title	Explanation	Default
ATCC_FastHigh_BPar_	Fast Higher Enable	Enabling fast higher control command	0
ATCC_FastLow_BPar_	Fast Lower Enable	Enabling fast lower control command	0

Table 3-109 The boolean parameters of the automatic tap changer controller function

Integer parameters

Parameter name	Title	Unit	Min	Max	Step	Default
Code value of the minimum position						
ATCC_MinPos_lpar_	Min Position		1	32	1	1
Code value of the maximum position						
ATCC_MaxPos_lpar_	Max Position		1	32	1	32

Table 3-110 The integer parameters of the automatic tap changer controller function

Timer parameters

Parameter name	Title	Unit	Min	Max	Step	Default
Time limit for tap-change operation						
ATCC_TimOut_TPar_	Max Operating Time	msec	1000	30000	1	5000
Command impulse duration						
ATCC_Pulse_TPar_	Pulse Duration	msec	100	10000	1	1000
Time overbridging the transient state of the tap changer status signals						
ATCC_MidPos_TPar_	Position Filter	msec	1000	30000	1	3000
Select before operate timeout, according to IEC 61850						
ATCC_SBOTimeout_TPar_	SBO Timeout	msec	1000	20000	1	5000

Table 3-111 The timer parameters of the automatic tap changer controller function

Float point parameters

Parameter name	Title	Unit	Min	Max	Digits	Default
Factor for fine tuning the measured voltage:						
ATCC_Ubias_FPar_	U Correction	-	0.950	1.050	3	1.000
Set-point for voltage regulation, related to the rated voltage (valid at I=0):						
ATCC_USet_FPar_	U Set	%	80.0	115.0	1	100.0
Dead band for voltage regulation, related to the rated voltage:						
ATCC_UDead_FPar_	U Deadband	%	0.5	9.0	1	3.0
Hysteresis value for the dead band, related to the dead band:						
ATCC_Deathyst_FPar_	Deadband Hysteresis	%	60	90	0	85
Parameter for the current compensation:						
ATCC_URinc_FPar_	(R) Compound Factor	%	0.0	15.0	1	5.0
Parameter for the current compensation:						
ATCC_UXinc_FPar_	X Compound Factor	%	0.0	15.0	1	5.0
Reduced set-point 1 for voltage regulation (priority), related to the rated voltage:						
ATCC_VRed1_FPar_	Voltage Reduction 1	%	0.0	10.0	1	5.0
Reduced set-point 2 for voltage regulation, related to the rated voltage:						
ATCC_VRed2_FPar_	Voltage Reduction 2	%	0.0	10.0	1	5.0
Maximum current value to be considered in current compensation formulas:						
ATCC_ICompLim_FPar_	I Comp Limit	%	0.00	150	0	1
Current upper limit to disable all operation:						
ATCC_IHVOC_FPar_	I Overload	%	50	150	0	100
Voltage upper limit to disable step up:.						
ATCC_UHigh_FPar_	U High Limit	%	90.0	120.0	1	110.0
Voltage lower limit to disable step down:						
ATCC_ULow_FPar_	U Low Limit	%	70.0	110.0	1	90.0
Voltage lower limit to disable all operation:						
ATCC_UBlock_FPar_	U Low Block	%	50.0	100.0	1	70.0
Time delay for the first control command generation:						
ATCC_T1_FPar_	T1	sec	1.0	600.0	1	10.0
Definite time delay for subsequent control command generation or fast operation (if it is enabled):						
ATCC_T2_FPar_	T2	sec	1.0	100.0	1	10.0
In case of dependent time characteristics, this is the minimum time delay						
ATCC_MinDel_FPar_	Min Delay	sec	1.0	100.0	1	10.0
After a control command, if the voltage is out of the range within the reclaim time, then the command is generated after T2 time delay						
ATCC_Recl_FPar_	Reclaim Time	sec	1.0	100.0	1	10.0

Table 3-112 The float parameters of the automatic tap changer controller function

3.2 Control & supervision functions

3.2.1 Phase-selective trip logic (TRC94_PhS)

The phase-selective trip logic function operates according to the functionality required by the IEC 61850 standard for the "Trip logical node".

The function receives the trip requirements of the protective functions implemented in the device and combines the parameters and the binary signals into the outputs of the device.

The trip requirements are programmed by the user, using the graphic equation editor. The decision logic has the following aims:

- define a minimal impulse duration even if the protection functions detect a very short time fault,
- in case of phase-to-phase faults, involve the third phase in the trip command,
- fulfill the requirements of the automatic reclosing function to generate a three-phase trip command even in case of single-phase faults,
- in case of an evolving fault, during the evolving fault waiting time include all three phases into the trip command.

The decision logic module combines the status signals and enumerated parameters to generate the trip commands on the output module of the device.

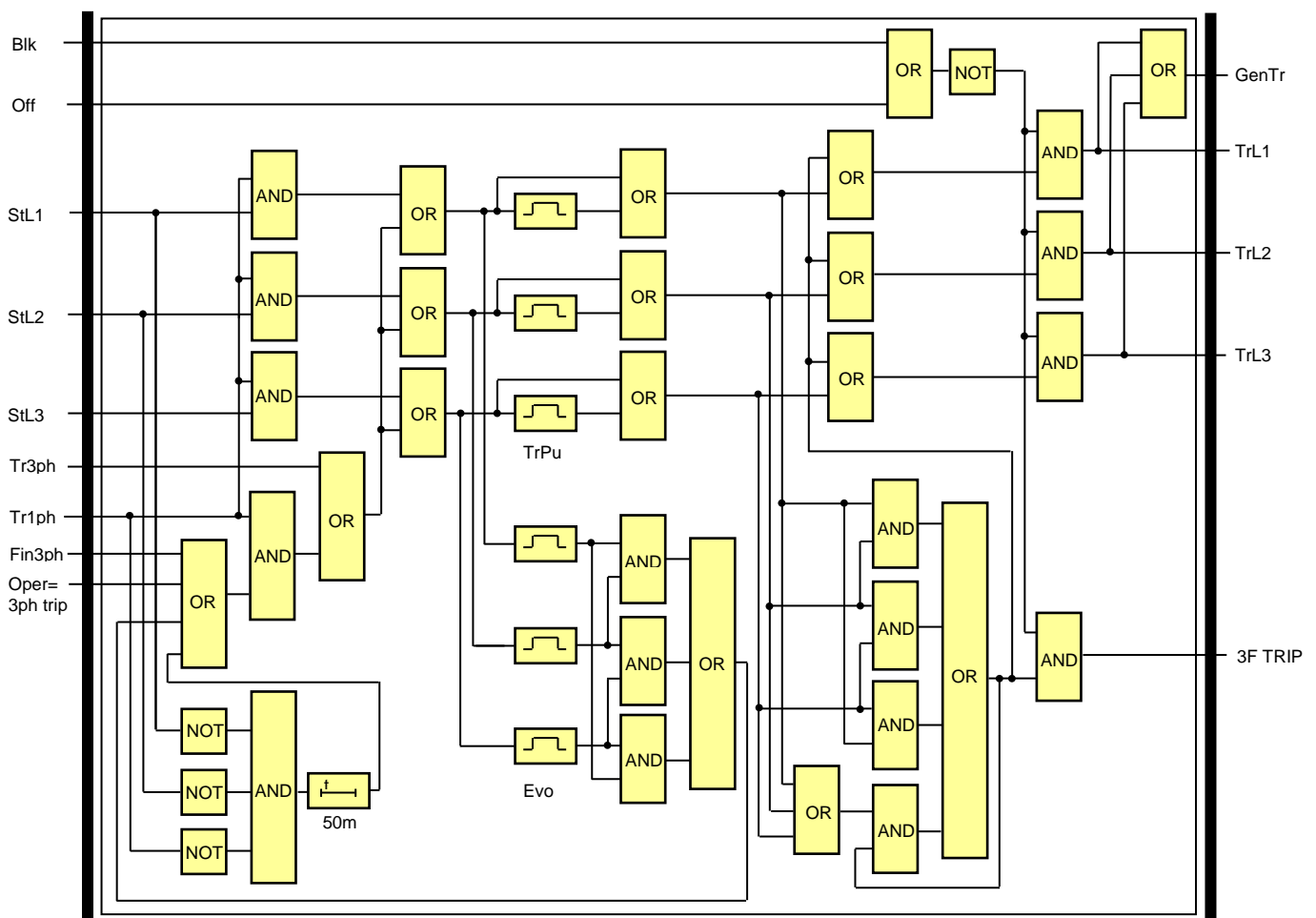

Figure 3-5 Decision logic of the phase-selective trip logic

Technical data

Function	Accuracy
Timer accuracy	±5% or ±15 ms, whichever is greater

Table 3-113 Technical data of the phase-selective trip logic function

Parameters

Enumerated parameter

Parameter name	Title	Selection range	Default
Selection of the operating mode			
TRC94_Oper_EPar_	Operation	Off, 3ph trip, 1ph/3ph trip	3ph trip

Tables 3-114 The enumerated parameter of the phase-selective trip logic function

Timer parameter

Parameter name	Title	Unit	Min	Max	Step	Default
Minimum duration of the generated impulse						
TRC94_TrPu_TPar_	Min Pulse Duration	msec	50	60000	1	150
Waiting time for evolving fault						
TRC94_Evo_TPar_	Evolving Fault Time	msec	50	60000	1	1000

Table 3-115 Timer parameter of the phase-selective trip logic function

3.2.2 Circuit breaker wear monitoring function (CBWear)

If a circuit breaker interrupts a current, the electric arc between the contacts results some metal loss. If the metal loss due to the burning of the electric arc becomes substantial, the contacts must be replaced.

Manufacturers define the permitted number of short circuits by formulas such as:

$$\sum_{i=1}^n I_i^k = CycNum$$

where

n = number of short circuits

k = exponent, calculated by the algorithm, based on the parameters

I = short-circuit current, kA (RMS)

CycNum = total value of weighted breaking currents.

Similar information is conveyed by the diagram below. This shows the number of permitted interruptions (logarithmic scaling) versus short-circuit current (logarithmic scaling).

Number of interruptions

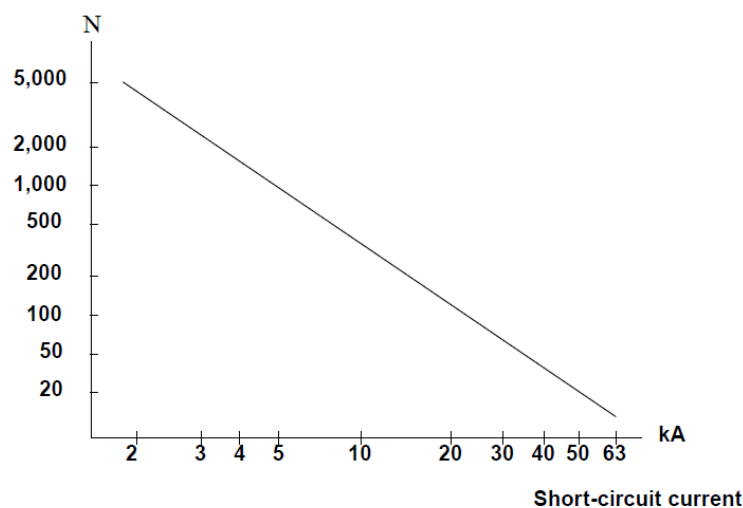

Example: Number of permitted interruptions as the function of the interrupted current

The straight line of the curve is defined by two points:

- The number of permitted interruptions of 1 kA current, by parameter "CycNum - 1kA"
- The permitted number of interruptions of the rated breaking current of the circuit breaker by parameter "CycNum - I Rated Trip". The rated breaking current of the circuit breaker is set by parameter "Rated Trip Current"

The circuit breaker wear monitoring function processes the Fourier basic harmonic component of the three phase currents.

The circuit breaker wear monitoring function finds the maximum value of the phase current of each interruption and calculates the wear caused by the operation performed. If the sum of the calculated wear reaches the limit, a warning signal is generated. This indicates the time of the required preventive maintenance of the circuit breaker.

The procedure of monitoring starts at the receipt of a trip command on the dedicated input (Trip). For the start of this procedure, the circuit breaker also needs to be in closed state. This signal is received on the dedicated binary input (CB Closed).

The procedure of identifying the maximum phase current value terminates when the current falls below the minimum current defined by the parameter Min Current AND the circuit breaker gets in open position. This signal is received on the dedicated binary input (CB Open).

The procedure also stops if the time elapsed since its start exceeds 1 s. In this case no CB wear is calculated.

Based on the characteristic defined above, the function calculates the wear caused by the operation performed. If the sum of the calculated wear reaches the limit defined by the parameter “CycNum – Alarm”, a warning signal is generated (Alarm). This indicates the advised time of the preventive maintenance of the circuit breaker.

The accumulated “wear” of the circuit breaker is stored on non-volatile memory; therefore, the value is not lost even if the power supply of the devices is switched off.

This information is displayed among the on-line data as “Actual wear”. This counter indicates how many 1 kA equivalent switches were performed since the last maintenance (reset).

When preventive maintenance is performed, the accumulated “wear” of the circuit breaker must be reset to 0 to start a new maintenance cycle. The circuit breaker wear monitoring function offers two ways of resetting:

- Binary True signal programmed to the “Reset” input of the function
- Performing a direct command via the Commands menu of the supervising WEB browser (for details, see the “Europrot+ manual”, “Remote user interface description” document).

The **inputs** of the circuit breaker wear monitoring function are

- the Fourier components of three phase currents,
- binary inputs,
- parameters.

The **output** of the circuit breaker wear monitoring function is

- the Alarm binary output status signal.

Technical data

Function	Range	Accuracy
Current accuracy	20 – 2000% of In	±1% of In
Accuracy in tracking the theoretical wear characteristics		5%

Table 3-116 Technical data of the circuit breaker wear monitoring function

Parameters

Enumerated parameters

Parameter name	Title	Selection range	Default
Disabling or enabling the operation of the function			
CBWear_Oper_EPar_	Operation	Off, On	Off

Table 3-117 Enumerated parameter of the circuit breaker wear monitoring function

Integer parameter

Parameter name	Title	Unit	Min	Max	Step	Default
Permitted number of trip operation if the breaking current is 1kA						
CBWear_CycNumIn_IPar_	CycNum - 1kA		1	100000	1	50000
Permitted number of trip operation if the breaking current is InTrip (see floating parameter “Rated Trip Current”)						
CBWear_CycNumInTrip_IPar_	CycNum – I Rated Trip		1	100000	1	100
Permitted level of the weighted sum of the breaking currents						
CBWear_CycNumAlm_IPar_	CycNum - Alarm		1	100000	1	50000

Table 3-118 Integer parameters of the circuit breaker wear monitoring function

Float point parameter

Parameter name	Title	Unit	Min	Max	Step	Default
Rated breaking current of the circuit breaker						
CBWear_InTrCB_FPar_	Rated Trip Current	kA	10	100	0.01	10
Minimum level of the current below which the procedure to find the highest breaking current is stopped						
CBWear_lmin_FPar_	Min Current	kA	0.10	0.50	0.01	0.10

Table 3-119 Float parameter of the circuit breaker wear monitoring function

Binary output status signal

Binary output status signal	Signal title	Explanation
Alarm signal of the function block		
CBWear_Alarm_Grl_	Alarm	Alarm signal is generated if the weighted sum of the breaking currents is above the permitted level

Table 3-120 Binary output status signal of the circuit breaker wear monitoring function

Binary input status signals

The **binary inputs** are signals influencing the operation of the circuit breaker wear monitoring function. These signals are the results of logic equations graphically edited by the user.

Binary input status signals	Signal title	Explanation
Disabling the function		
CBWear_Blk_GrO_	Blk	The programmed True state of this input disables the operation of the function
Open state of the circuit breaker		
CBWear_Open_GrO_	Open	The open state of the circuit breaker is needed to stop the procedure to find the maximum breaking current
Closed state of the circuit breaker		
CBWear_Closed_GrO_	Closed	The closed state of the circuit breaker is needed to perform the procedure to find the maximum breaking current
Trip command to the circuit breaker		
CBWear_Trip_GrO_	Trip	This signal starts the procedure to find the highest breaking current
Reset command		
CBWear_Reset_GrO_	Reset	If this input is programmed to logic True, at maintenance the weighted sum of the breaking currents can be set to 0

Table 3-121 Binary input status signals of the circuit breaker wear monitoring function

3.2.3 Circuit breaker control function block (CB1PoI)

The Circuit breaker control function block can be used to integrate the circuit breaker control of the EuroProt+ device into the station control system and to apply active scheme screens of the local LCD of the device.

The Circuit breaker control function block receives remote commands from the SCADA system and local commands from the local LCD of the device, performs the prescribed checking and transmits the commands to the circuit breaker. It processes the status signals received from the circuit breaker and offers them to the status display of the local LCD and to the SCADA system.

Main features:

- Local (LCD of the device) and Remote (SCADA) operation modes can be enabled or disabled individually.
- The signals and commands of the synchro check / synchro switch function block can be integrated into the operation of the function block.
- Interlocking functions can be programmed by the user applying the inputs “EnaOff” (enabled trip command) and “EnaOn” (enabled close command), using the graphic equation editor.
- Programmed conditions can be used to temporarily disable the operation of the function block using the graphic equation editor.
- The function block supports the control models prescribed by the IEC 61850 standard.
- All necessary timing tasks are performed within the function block:
 - Time limitation to execute a command
 - Command pulse duration
 - Filtering the intermediate state of the circuit breaker
 - Checking the synchro check and synchro switch times
 - Controlling the individual steps of the manual commands
- Sending trip and close commands to the circuit breaker (to be combined with the trip commands of the protection functions and with the close command of the automatic reclosing function; the protection functions and the automatic reclosing function directly gives commands to the CB). The combination is made graphically using the graphic equation editor
- Operation counter
- Event reporting

The Circuit breaker control function block has binary input signals. The conditions are defined by the user applying the graphic equation editor. The signals of the circuit breaker control are seen in the binary input status list.

Technical data

Function	Accuracy
Operate time accuracy	±5% or ±15 ms, whichever is greater

Table 3-122 Technical data of the circuit breaker control function

Parameters

Enumerated parameter

Parameter name	Title	Selection range	Default
The control model of the circuit breaker node according to the IEC 61850 standard			
CB1Pol_ctlMod_EPar_	ControlModel*	Direct normal, Direct enhanced, SBO enhanced	Direct normal

**ControlModel*

- Direct normal: only command transmission
- Direct enhanced: command transmission with status check and command supervision
- SBO enhanced: Select Before Operate mode with status check and command supervision

Table 3-123 Enumerated parameter of the circuit breaker control function

Boolean parameter

Boolean parameter	Title	Explanation
CB1Pol_DisOverR_BPar_	Forced check	If true, then the check function cannot be neglected by the check attribute defined by the IEC 61850 standard

Table 3-124 Boolean parameter of the circuit breaker control function

Timer parameters

Parameter name	Title	Unit	Min	Max	Step	Default
Timeout for signaling failed operation						
CB1Pol_TimOut_TPar_	Max.Operating time	msec	10	1000	1	200
Duration of the generated On and Off impulse						
CB1Pol_Pulse_TPar_	Pulse length	msec	50	500	1	100
Waiting time, at expiry intermediate state of the CB is reported						
CB1Pol_MidPos_TPar_	Max.Intermediate time	msec	20	30000	1	100
Length of the time period to wait for the conditions of the synchron state. After expiry of this time, the synchro switch procedure is initiated (see synchro check/ synchro switch function block description)						
CB1Pol_SynTimOut_TPar_	Max.SynChk time	msec	10	5000	1	1000
Length of the time period to wait for the synchro switch impulse (see synchro check/ synchro switch function block description). After this time the function resets, no switching is performed						
CB1Pol_SynSWTimOut_TPar_	Max.SynSW time*	msec	0	60000	1	0
Duration of the waiting time between object selection and command selection. At timeout no command is performed						
CB1Pol_SBOTimeout_TPar_	SBO Timeout	msec	1000	20000	1	5000

* If this parameter is set to 0, then the "StartSW" output is not activated

Table 3-125 Timer parameters of the circuit breaker control function

Available internal status variable and command channel

To generate an active scheme on the local LCD, there is an internal status variable indicating the state of the circuit breaker. Different graphic symbols can be assigned to the values. (See Chapter 3.2 of the document “EuroCAP configuration tool for EuroProt+ devices”).

Status variable	Title	Explanation
CB1Pol_stVal_Ist_	Status	Can be: 0: Intermediate 1: Off 2: On 3: Bad

The available control channel to be selected is:

Command channel	Title	Explanation
CB1Pol_Oper_Con_	Operation	Can be: On Off

Using this channel, the pushbuttons on the front panel of the device can be assigned to close or open the circuit breaker. These are the “Local commands”.

3.2.5 Disconnecter control function (DisConn)

The Disconnecter control function block can be used to integrate the disconnecter control of the EuroProt+ device into the station control system and to apply active scheme screens of the local LCD of the device.

The Disconnecter control function block receives remote commands from the SCADA system and local commands from the local LCD of the device, performs the prescribed checking and transmits the commands to the disconnecter. It processes the status signals received from the disconnecter and offers them to the status display of the local LCD and to the SCADA system.

Main features:

- Local (LCD of the device) and Remote (SCADA) operation modes can be enabled or disabled individually.
- Interlocking functions can be programmed by the user applying the inputs “EnaOff” (enabled trip command) and “EnaOn” (enabled close command), using the graphic equation editor.
- Programmed conditions can be used to temporarily disable the operation of the function block using the graphic equation editor.
- The function block supports the control models prescribed by the IEC 61850 standard.
- All necessary timing tasks are performed within the function block:
 - Time limitation to execute a command
 - Command pulse duration
 - Filtering the intermediate state of the disconnecter
 - Controlling the individual steps of the manual commands
- Sending trip and close commands to the disconnecter
- Operation counter
- Event reporting

The Disconnecter control function block has binary input signals. The conditions are defined by the user applying the graphic equation editor. The signals of the disconnecter control are seen in the binary input status list.

Technical data

Function	Accuracy
Operate time accuracy	±5% or ±15 ms, whichever is greater

Table 3-126 Technical data of the disconnecter control function

Parameters

Enumerated parameters

Parameter name	Title	Selection range	Default
The control model of the disconnecter node according to the IEC 61850 standard			
DisConn_ctlMod_EPar_	ControlModel*	Direct normal, Direct enhanced, SBO enhanced	Direct normal
Type of switch			
DisConn_SwTyp_EPar_	Type of Switch	N/A, Load break, Disconnecter, Earthing Switch, HS Earthing Switch	Disconnecter

*ControlModel

- Direct normal: only command transmission
- Direct enhanced: command transmission with status check and command supervision
- SBO enhanced: Select Before Operate mode with status check and command supervision

Table 3-127 Enumerated parameters of the disconnecter control function

Boolean parameter

Boolean parameter	Title	Explanation
DisConn_DisOverR_BPar_	Forced check	If true, then the check function cannot be neglected by the check attribute defined by the IEC 61850 standard

Table 3-128 Boolean parameter of the disconnector control function

Timer parameters

Parameter name	Title	Unit	Min	Max	Step	Default
Timeout for signaling failed operation						
DisConn_TimOut_TPar_	Max.Operating time	msec	10	20000	1	1000
Duration of the generated On and Off impulse						
DisConn_Pulse_TPar_	Pulse length	msec	50	30000	1	100
Waiting time, at expiry intermediate state of the disconnector is reported						
DisConn_MidPos_TPar_	Max.Intermediate time	msec	20	30000	1	100
Duration of the waiting time between object selection and command selection. At timeout no command is performed						
DisConn_SBOTimeout_TPar_	SBO Timeout	msec	1000	20000	1	5000

Table 3-129 Timer parameters of the disconnector control function

Available internal status variable and command channel

To generate an active scheme on the local LCD, there is an internal status variable indicating the state of the disconnector. Different graphic symbols can be assigned to the values. (See Chapter 3.2 of the document “EuroCAP configuration tool for EuroProt+ devices”).

Status variable	Title	Explanation
DisConn_l_stVal_1st_	Status	Can be: 0: Intermediate 1: Off 2: On 3:Bad

The available control channel to be selected is:

Command channel	Title	Explanation
DisConn_Oper_Con_	Operation	Can be: On Off

Using this channel, the pushbuttons on the front panel of the device can be assigned to close or open the disconnector. These are the “Local commands”.

3.2.6 Ethernet Links function (EthLinks)

The EuroProt+ device constantly checks the statuses of its connections to the outside world (wherever possible). These statuses can be seen on the **status/log** page in the advanced menu on the web page of the device.

When further indications are needed or the signals of the statuses (such as events, logic signals for the user logic, LEDs etc.), the Ethernet Links function block makes these available for the user.

Ports

The function can check the following types of communication ports:

- Fiber Optic (MM – multi mode)
- Fiber Optic (SM – single mode)
- RJ45
- PRP/HSR
- EOB (Ethernet On Board on the front HMI of the device)

See the EuroProt+ Hardware Description (different document) for the list of the CPU modules that contain any of these ports.

Ethernet Links function overview

The graphic appearance of the function block is shown on Figure 3-6. These blocks show all binary input and output status signals, which are applicable in the graphic equation editor.

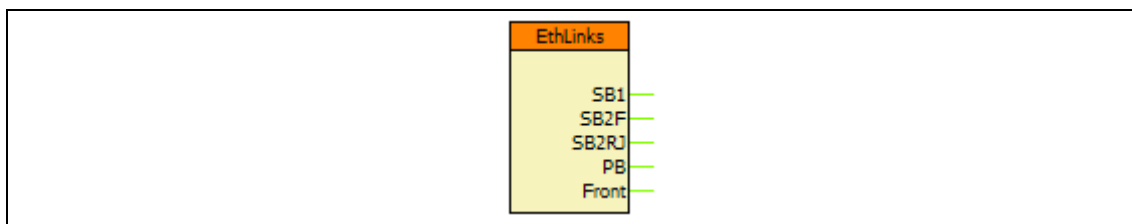

Figure 3-6 Graphic appearance of the function block of the ethernet links function

Function I/O

This section describes briefly the analogue and digital inputs and outputs of the function block.

This function block owns only binary output signals.

Binary output signals (graphed input statuses)

The binary output status signals of the Ethernet Links function. **Parts written in bold** are seen on the function block in the logic editor.

BINARY OUTPUT SIGNAL	SIGNAL TITLE	EXPLANATION
EthLnk_ SB1 _Grl_	Station Bus1	Active if the first (upper) fiber optic port of the CPU module has an active connection.
EthLnk_ SB2F _Grl_	Station Bus2 – Fiber	Active if the second (middle) fiber optic port of the CPU module has an active connection.
EthLnk_ SB2RJ _Grl_	Station Bus2 –RJ4	Active if the RJ45 port of the CPU module has an active connection.
EthLnk_ PB _Grl_	Process Bus	Active if the third (lower) fiber optic port of the CPU module has an active connection
EthLnk_ Front _Grl_	RJ45/EOB on front panel	Active if the front RJ45 port (or EOB) has an active connection

Table 3-130 The binary output status signals of the ethernet links function

On-line data

Visible values on the on-line data page:

SIGNAL TITLE	DIMENSION	EXPLANATION
Station Bus1	-	Active if the first (upper) fiber optic port of the CPU module has an active connection.
Station Bus2 – Fiber	-	Active if the second (middle) fiber optic port of the CPU module has an active connection.
Station Bus2 –RJ4	-	Active if the RJ45 port of the CPU module has an active connection.
Process Bus	-	Active if the third (lower) fiber optic port of the CPU module has an active connection
RJ45/EOB on front panel	-	Active if the front RJ45 port (or EOB) has an active connection

Table 3-131 The measured analogue values of the ethernet links function

Events

The following events are generated in the event list, as well as sent to SCADA according to the configuration.

EVENT	VALUE	EXPLANATION
Station Bus1	off, on	Active if the first (upper) fiber optic port of the CPU module has an active connection.
Station Bus2 – Fiber	off, on	Active if the second (middle) fiber optic port of the CPU module has an active connection.
Station Bus2 –RJ4	off, on	Active if the RJ45 port of the CPU module has an active connection.
Process Bus	off, on	Active if the third (lower) fiber optic port of the CPU module has an active connection
RJ45/EOB on front panel	off, on	Active if the front RJ45 port (or EOB) has an active connection

Table 3-132 Events of the ethernet links function

3.2.7 Trip Circuit Supervision (TCS)

The trip circuit supervision is utilized for checking the integrity of the circuit between the trip coil and the tripping output of the protection device.

It is realized by injecting a small DC current (around 1-5 mA) into the trip circuit. If the circuit is intact, the current flows, which lights up a LED that provides an active signal to the opto coupler input of the trip contact.

The state of the input is shown on the devices' binary input listing among the other binary inputs, and it can be handled like any other of them (it can be added to the user logic, etc.)

This document describes the applicable hardware and provides guidelines for usage in the device configuration.

Hardware application

Applicable modules

The following modules contain trip outputs with trip circuit supervision. The information here is restricted to the trip circuit supervision only. For more details please refer to the EuroProt+ Hardware description from which these were extracted. Note that there are other modules without trip circuit supervision, those are not listed here.

MODULE TYPE	TRIP+4201	TRIP+2101	TRIP+2201	PSTP+4201	PSTP+2101
CHANNEL NUMBER	4	4	4	2	2
RATED VOLTAGE	24 V DC and 48 V DC	110 V DC	220 V DC	24 V DC and 48 V DC and 60 V DC	110 V DC and 220 V DC
THERMAL WITHSTAND VOLTAGE	72 V DC	132 V DC	242 V DC	72 V DC	242 V DC

Table 3-133 Modules with Trip Circuit Supervision

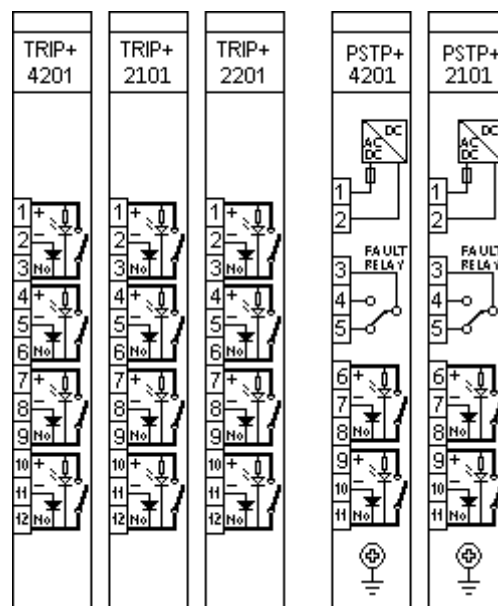

Figure 3-7 I/O arrangement of the modules with TCS

Wiring

The wiring of these modules can be 2-wire or 3-wire. (TCS function is active for both methods.)

The voltage of the "No" contact is maximized at 15 V by a zener-diode. Make sure that the voltage caused by the resistance of the circuit breaker and the injected current from the TRIP+ module does not reach 10 V.

Our TRIP+ modules are made to switch DC circuits. **Using reversed polarity or AC voltage can cause the damage of the internal circuits.**

3-wire TRIP+ wiring methods

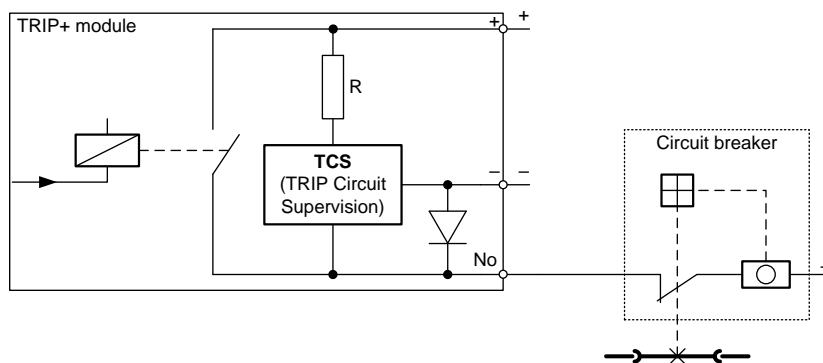

Figure 3-8 3-wire TRIP+ wiring

It is possible to use parallel connected TRIP+ modules. In this case the negative contacts must be common.

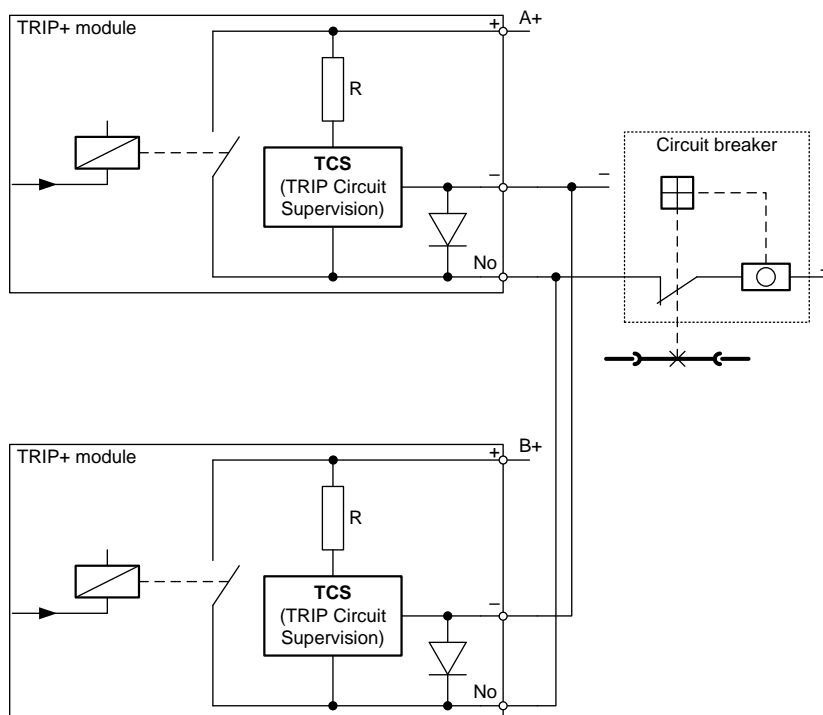

Figure 3-9 3-wire TRIP+ wiring using parallel connected TRIP+ modules

2-wire TRIP+ wiring methods

If it is necessary, you can also wire the TRIP+ modules using only the “+” and the “No” contacts.

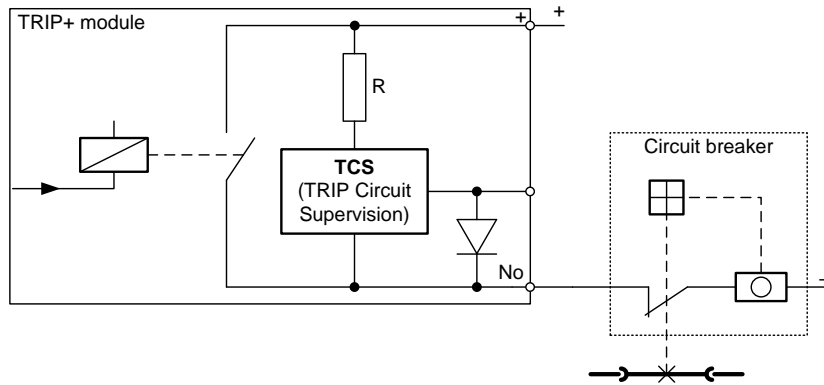

Figure 3-10 2-wire TRIP+ wiring

It is possible to use parallel connected TRIP+ modules.

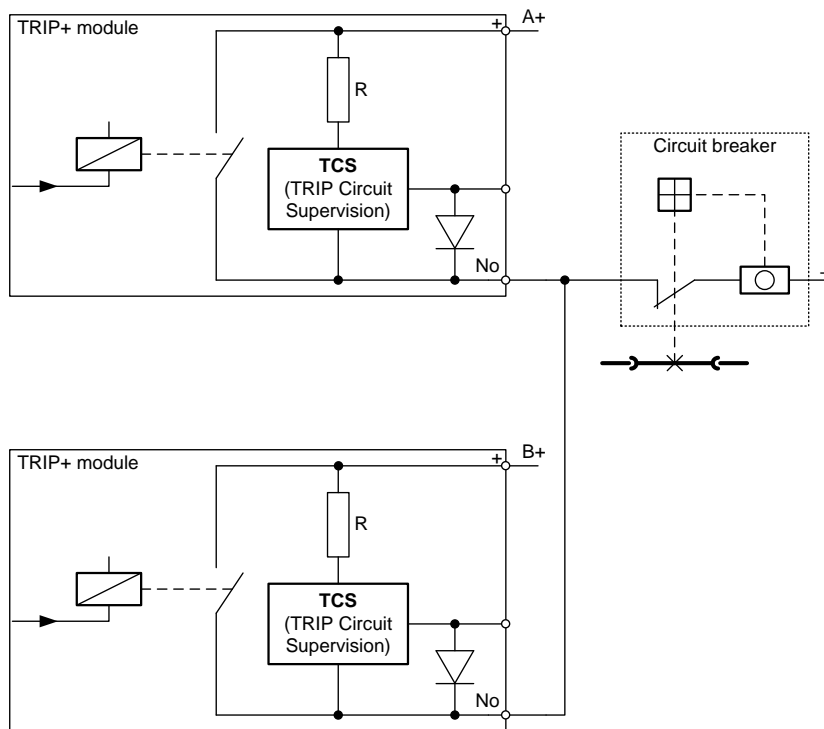

Figure 3-11 2-wire TRIP+ wiring using parallel connected TRIP+ modules

If the circuit breaker needs two-pole switching TRIP+ modules can be connected series as you can see in Figure 3-12.

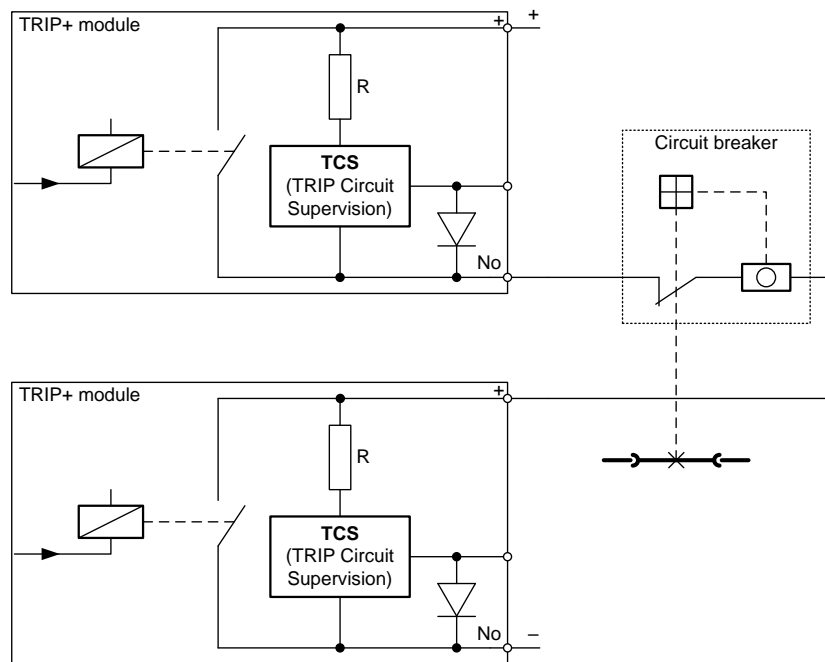

Figure 3-12 2-wire TRIP+ wiring using series connected TRIP+ modules

MODULE TYPE	TRIP+4201	TRIP+2101	TRIP+2201
VALUE OF R RESISTOR ($\pm 10\%$)	10 k Ω	73 k Ω	130 k Ω
INJECTED CURRENT AT "No" CONTACT	2.4 mA @ 24 V DC 4.8 mA @ 48 V DC	1.5 mA @ 110 V DC	1.7 mA @ 220 V DC

Figure 3-13 Technical data for the TRIP modules

Software application

Binary inputs

The **TCS input is active if the trip circuit is OK**, so the logical '0' or FALSE signal of the input means that either the trip circuit is broken (see Chapter 0 for the case when this is mandatory with the CB trip), or it connects to a high-resistance part.

The TCS signals are shown the same way as other binary inputs are in the device: they can be seen in the **on-line data** menu on the local HMI or the device web page, and they can be utilized just like any other binary input when editing the device configuration with EuroCAP software.

The names/titles of the inputs might be a bit different: it may be according to the corresponding TRIP outputs (if the TRIP module is in Slot **N**, the TCS contact is named **BIn_N##**), or if there is only one module with TRIP outputs, the TCS inputs might be named as TCS1, TCS2 etc. These can be checked (and the titles can be modified) in the devices' configuration file using the EuroCAP software.

The TCS macro

In several cases the trip circuit is tripped along with the circuit breaker as well. In situations like this the TCS input would signal a broken trip circuit (logical '0' or FALSE) unnecessarily. To avoid this, the status signals of the CB are to be used combined with the TCS input signal so that it will be evaluated only when the CB is closed.

The TCS macro incorporates this logic for two separate TCS inputs for one CB (see Figure 3-15 for the two TCS inputs and the CB status signal inputs). The outputs are the failure signals for each connected TCS input.

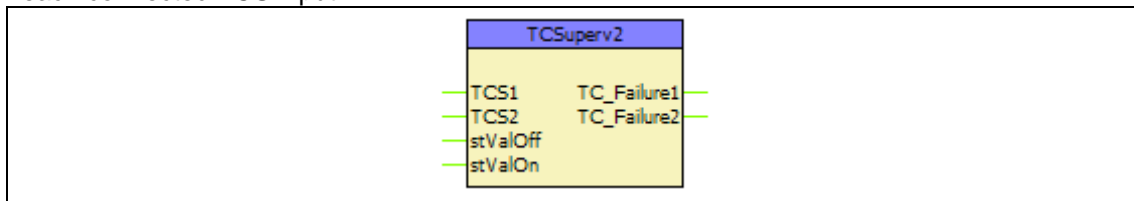

Figure 3-14 Graphic appearance of the Trip Circuit Supervision macro

The internal logic of the macro can be seen on Figure 3-15 below. Both outputs have a fixed pick delay of 1000 ms. Note that **here the outputs are active if the trip circuit is broken** (or there is a failure in it). For a CB with only 1 trip circuit it is enough to simply leave the **TCS2** input open.

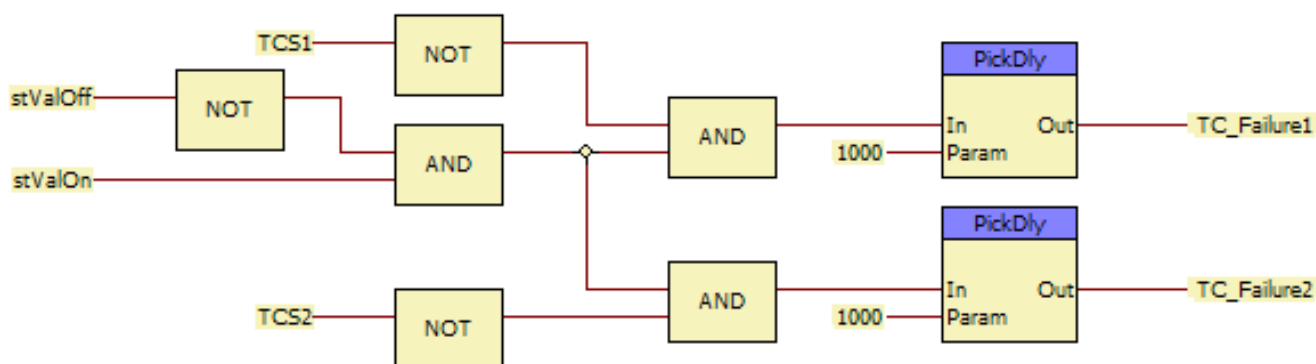

Figure 3-15 Internal logic of the Trip Circuit Supervision macro

Binary input signals

The following table explains the binary input signals of the macro.

BINARY INPUT SIGNAL	EXPLANATION
TCS1	Connect here the first TCS binary input
TCS2	Connect here the second TCS binary input
stValOff	CB Off/Open signal
stValOn	CB On/Closed signal

Table 3-134 Binary input signals of the Trip Circuit Supervision macro

Binary output signals

The following table explains the binary output signals of the macro.

BINARY OUTPUT SIGNAL	EXPLANATION
TC_Failure1	Failure on the first circuit
TC_Failure2	Failure on the second circuit

Table 3-135 Binary output signals of the Trip Circuit Supervision macro

Note that these are the outputs of a macro, and not a function block, so they must be connected to a physical or a logical output (ConnOut, create status) to make them usable in other parts of the configuration. For further information please refer to the EuroCAP software description.

3.2.8 Dead line detection function (DLD)

The “Dead Line Detection” (DLD) function generates a signal indicating the dead or live state of the line. Additional signals are generated to indicate if the phase voltages and phase currents are above the pre-defined limits.

The task of the “Dead Line Detection” (DLD) function is to decide the Dead line/Live line state.

Criteria of “Dead line” state: all three phase voltages are below the voltage setting value AND all three currents are below the current setting value.

Criteria of “Live line” state: all three phase voltages are above the voltage setting value.

The details are described in the document ***Dead line detection protection function block description.***

Technical data

Function	Value	Accuracy
Pick-up voltage		1%
Operation time	<20ms	
Reset ratio	0.95	

Table 3-136 Technical data of the dead line detection function

Parameters

Integer parameters

Parameter name	Title	Unit	Min	Max	Step	Default
Integer parameters of the dead line detection function						
DLD_ULev_IPar_	Min. Operate Voltage	%	10	100	1	60
DLD_ILev_IPar_	Min. Operate Current	%	2	100	1	10

Table 3-137 The integer parameters of the dead line detection function

3.2.9 Voltage transformer supervision function (VTS60)

The voltage transformer supervision function generates a signal to indicate an error in the voltage transformer secondary circuit. This signal can serve, for example, as a warning, indicating disturbances in the measurement, or it can disable the operation of the distance protection function if appropriate measured voltage signals are not available for a distance decision.

The voltage transformer supervision function is designed to detect faulty asymmetrical states of the voltage transformer circuit caused, for example, by a broken conductor in the secondary circuit.

(Another method for detecting voltage disturbances is the supervision of the auxiliary contacts of the miniature circuit breakers in the voltage transformer secondary circuits. This function is not described here.)

The user has to generate graphic equations for the application of the signal of this voltage transformer supervision function.

This function is interconnected with the “dead line detection function”. Although the dead line detection function is described fully in a separate document, the explanation necessary to understand the operation of the VT supervision function is repeated also in this document.

The voltage transformer supervision function can be used in three different modes of application:

Zero sequence detection (for typical applications in systems with grounded neutral): “VT failure” signal is generated if the residual voltage ($3U_0$) is above the preset voltage value AND the residual current ($3I_0$) is below the preset current value.

Negative sequence detection (for typical applications in systems with isolated or resonant grounded (Petersen) neutral): “VT failure” signal is generated if the negative sequence voltage component (U_2) is above the preset voltage value AND the negative sequence current component (I_2) is below the preset current value.

Special application: “VT failure” signal is generated if the residual voltage ($3U_0$) is above the preset voltage value AND the residual current ($3I_0$) AND the negative sequence current component (I_2) are below the preset current values.

The voltage transformer supervision function can be activated if “Live line” status is detected for at least 200 ms. This delay avoids mal-operation at line energizing if the poles of the circuit breaker make contact with a time delay. The function is set to be inactive if “Dead line” status is detected.

If the conditions specified by the selected mode of operation are fulfilled (for at least 4 milliseconds) then the voltage transformer supervision function is activated and the operation signal is generated. (When evaluating this time delay, the natural operating time of the applied Fourier algorithm must also be considered.)

NOTE: For the operation of the voltage transformer supervision function the “Dead line detection function” must be operable as well: it must be enabled by binary parameter setting, and its blocking signal may not be active.

If, in the active state, the conditions for operation are no longer fulfilled, the resetting of the function depends on the mode of operation of the primary circuit:

- If the “Live line” state is valid, then the function resets after approx. 200 ms of time delay. (When evaluating this time delay, the natural operating time of the applied Fourier algorithm must also be considered.)
- If the “Dead line” state is started and the “VTS Failure” signal has been continuous for at least 100 ms, then the “VTS failure” signal does not reset; it is generated continuously even when the line is in a disconnected state. Thus, the “VTS Failure” signal remains active at reclosing.
- If the “Dead line” state is started and the “VTS Failure” signal has not been continuous for at least 100 ms, then the “VTS failure” signal resets.

Technical data

Function	Value	Accuracy
Pick-up voltage I ₀ =0A I ₂ =0A		<1% <1%
Operation time	<20ms	
Reset ratio	0.95	

Table 3-138 Technical data of the voltage transformer supervision function

Parameters

Integer parameters

Parameter name	Title	Unit	Min	Max	Step	Default
Integer parameters of the dead line detection function						
DLD_ULev_IPar_	Min Operate Voltage	%	10	100	1	60
DLD_ILev_IPar_	Min Operate Current	%	2	100	1	10
Starting voltage and current parameter for residual and negative sequence detection:						
VTS_Uo_IPar_	Start URes	%	5	50	1	30
VTS_Io_IPar_	Start IRes	%	10	50	1	10
VTS_Uneg_IPar_	Start UNeg	%	5	50	1	10
VTS_Ineg_IPar_	Start INeg	%	10	50	1	10

Table 3-139 The integer parameters of the voltage transformer supervision function

Enumerated parameter

Parameter name	Title	Selection range	Default
Parameter for type selection			
VTS_Oper_EPar_	Operation	Off, Zero sequence, Neg. sequence, Special	Zero sequence

Table 3-140 The enumerated parameter of the voltage transformer supervision function

3.2.10 Current unbalance function (VCB60)

The current unbalance protection function (VCB60) can be applied to detect unexpected asymmetry in current measurement.

The applied method selects maximum and minimum phase currents (RMS value of the fundamental Fourier components). If the difference between them is above the setting limit, the function generates a start signal. It is a necessary precondition of start signal generation that the maximum of the currents be above 10 % of the rated current and below 150% of the rated current.

The Fourier calculation modules calculate the RMS value of the basic Fourier current components of the phase currents individually. They are not part of the VCB60 function; they belong to the preparatory phase.

The analog signal processing module processes the RMS value of the basic Fourier current components of the phase currents to prepare the signals for the decision. It calculates the maximum and the minimum value of the RMS values and the difference between the maximum and minimum of the RMS values of the fundamental Fourier components of the phase currents as a percentage of the maximum of these values ($\Delta I >$). If the maximum of the currents is above 10 % of the rated current and below 150% of the rated current and the $\Delta I >$ value is above the limit defined by the preset parameter (Start Current Diff) an output is generated to the decision module.

The decision logic module combines the status signals to generate the starting signal and the trip command of the function.

The trip command is generated after the defined time delay if trip command is enabled by the Boolean parameter setting.

The function can be disabled by parameter setting, and by an input signal programmed by the user with the graphic programming tool.

Technical data

Function	Value	Accuracy
Pick-up starting accuracy at In		< 2 %
Reset ratio	0.95	
Operate time	70 ms	

Table 3-141 Technical data of the current unbalance function

Parameters

Enumerated parameter

Parameter name	Title	Selection range	Default
Selection of the operating mode			
VCB60_Oper_EPar_	Operation	Off, On	On

Table 3-142 The enumerated parameter of the current unbalance function

Boolean parameter

Parameter name	Title	Explanation	Default
Selection for trip command			
VCB60_StOnly_BPar_	Start Signal Only	0 to generate trip command	0

Table 3-143 The boolean parameter of the current unbalance function

Integer parameter

Parameter name	Title	Unit	Min	Max	Step	Default
Phase difference current setting						
VCB60_StCurr_IPar_	Start Current Diff	%	10	90	1	50

Table 3-144 The integer parameter of the current unbalance function

Timer parameter

Parameter name	Title	Unit	Min	Max	Step	Default
Time delay						
VCB60_Del_TPar_	Time Delay	msec	100	60000	100	1000

Table 3-145 The timer parameter of the current unbalance function

3.3 Measuring functions

The measured values can be checked on the touch-screen of the device in the “On-line functions” page, or using an Internet browser of a connected computer. The displayed values are secondary voltages and currents, except the block “Line measurement”. This specific block displays the measured values in primary units, using VT and CT primary value settings.

Analog value	Explanation
VT4 module	
Voltage Ch – U1	RMS value of the Fourier fundamental harmonic voltage component in phase L1
Angle Ch – U1	Phase angle of the Fourier fundamental harmonic voltage component in phase L1*
Voltage Ch – U2	RMS value of the Fourier fundamental harmonic voltage component in phase L2
Angle Ch – U2	Phase angle of the Fourier fundamental harmonic voltage component in phase L2*
Voltage Ch – U3	RMS value of the Fourier fundamental harmonic voltage component in phase L3
Angle Ch – U3	Phase angle of the Fourier fundamental harmonic voltage component in phase L3*
Voltage Ch – U4	RMS value of the Fourier fundamental harmonic voltage component in Channel U4
Angle Ch – U4	Phase angle of the Fourier fundamental harmonic voltage component in Channel U4*
CT4 module	
Current Ch - I1	RMS value of the Fourier fundamental harmonic current component in phase L1
Angle Ch - I1	Phase angle of the Fourier fundamental harmonic current component in phase L1*
Current Ch - I2	RMS value of the Fourier fundamental harmonic current component in phase L2
Angle Ch - I2	Phase angle of the Fourier fundamental harmonic current component in phase L2*
Current Ch - I3	RMS value of the Fourier fundamental harmonic current component in phase L3
Angle Ch - I3	Phase angle of the Fourier fundamental harmonic current component in phase L3*
Current Ch - I4	RMS value of the Fourier fundamental harmonic current component in Channel I4
Angle Ch - I4	Phase angle of the Fourier fundamental harmonic current component in Channel I4*
<i>Distance protection function (DIS21_HV)</i>	
Fault location	Measured distance to fault
Fault react.	Measured reactance in the fault loop
L1N loop R	Resistive component value of impedance in L1-N loop
L1N loop X	Reactive component value of impedance in L1-N loop
L2N loop R	Resistive component value of impedance in L2-N loop
L2N loop X	Reactive component value of impedance in L2-N loop
L3N loop R	Resistive component value of impedance in L3-N loop
L3N loop X	Reactive component value of impedance in L3-N loop
L12 loop R	Resistive component value of impedance in L12 loop
L12 loop X	Reactive component value of impedance in L12 loop
L23 loop R	Resistive component value of impedance in L23 loop
L23 loop X	Reactive component value of impedance in L23 loop
L31 loop R	Resistive component value of impedance in L31 loop
L31 loop X	Reactive component value of impedance in L31 loop

<i>Synchrocheck function (SYN25)</i>	
Voltage Diff	Voltage different value
Frequency Diff	Frequency different value
Angle Diff	Angle different value
<i>Line measurement (MXU_L) (here the displayed information means primary value)</i>	
Active Power – P	Three-phase active power
Reactive Power – Q	Three-phase reactive power
Apparent Power – S	Three-phase power based on true RMS voltage and current measurement
Current L1	True RMS value of the current in phase L1
Current L2	True RMS value of the current in phase L2
Current L3	True RMS value of the current in phase L3
Voltage L1	True RMS value of the voltage in phase L1
Voltage L2	True RMS value of the voltage in phase L2
Voltage L3	True RMS value of the voltage in phase L3
Voltage L12	True RMS value of the voltage between phases L1 L2
Voltage L23	True RMS value of the voltage between phases L2 L3
Voltage L31	True RMS value of the voltage between phases L3 L1
Frequency	Frequency
<i>Metering (MTR)</i>	
Forward MWh	Forward MWh
Backward MWh	Backward MWh
Forward MVarh	Forward MVarh
Backward MVarh	Backward MVarh
<i>Line thermal protection (TTR49L)</i>	
Calc. Temperature	Calculated line temperature

* The reference angle is the phase angle of "Voltage Ch - U1"

Table 3-146 Measured analog values

3.3.1 Current input function (CT4)

If the factory configuration includes a current transformer hardware module, the current input function block is automatically configured among the software function blocks. Separate current input function blocks are assigned to each current transformer hardware module.

A current transformer hardware module is equipped with four special intermediate current transformers. (See Chapter 5 of the EuroProt+ hardware description document.) As usual, the first three current inputs receive the three phase currents (IL1, IL2, IL3), the fourth input is reserved for zero sequence current, for the zero sequence current of the parallel line or for any additional current. Accordingly, the first three inputs have common parameters while the fourth current input needs individual setting.

The role of the current input function block is to

- set the required parameters associated to the current inputs,
- deliver the sampled current values for disturbance recording,
- perform the basic calculations
 - Fourier basic harmonic magnitude and angle,
 - True RMS value;
- provide the pre-calculated current values to the subsequent software modules,
- deliver the basic calculated values for on-line displaying.

Operation of the current input algorithm

The current input function block receives the sampled current values from the internal operating system. The scaling (even hardware scaling) depends on parameter setting. See parameters CT4_Ch13Nom_EPar_ (Rated Secondary I1-3) and CT4_Ch4Nom_EPar_ (Rated Secondary I4). The options to choose from are 1A or 5A (in special applications, 0.2A or 1A). This parameter influences the internal number format and, naturally, accuracy. (A small current is processed with finer resolution if 1A is selected.)

If needed, the phase currents can be inverted by setting the parameter CT4_Ch13Dir_EPar_ (Starpoint I1-3). This selection applies to each of the channels IL1, IL2 and IL3. The fourth current channel can be inverted by setting the parameter CT4_Ch4Dir_EPar (Direction I4). This inversion may be needed in protection functions such as distance protection, differential protection or for any functions with directional decision.

These sampled values are available for further processing and for disturbance recording.

The performed basic calculation results the Fourier basic harmonic magnitude and angle and the true RMS value. These results are processed by subsequent protection function blocks and they are available for on-line displaying as well.

The function block also provides parameters for setting the primary rated currents of the main current transformer. This function block does not need that parameter setting. These values are passed on to function blocks such as displaying primary measured values, primary power calculation, etc.

Technical data

Function	Range	Accuracy
Current accuracy	20 – 2000% of I _n	±1% of I _n

Table 3-147 Technical data of the current input

Parameters

Enumerated parameters

Parameter name	Title	Selection range	Default
Rated secondary current of the first three input channels. 1A or 5A is selected by parameter setting, no hardware modification is needed.			
CT4_Ch13Nom_EPar_	Rated Secondary I1-3	1A,5A	1A
Rated secondary current of the fourth input channel. 1A or 5A is selected by parameter setting, no hardware modification is needed.			
CT4_Ch4Nom_EPar_	Rated Secondary I4	1A,5A (0.2A or 1A)	1A
Definition of the positive direction of the first three currents, given by location of the secondary star connection point			
CT4_Ch13Dir_EPar_	Starpoint I1-3	Line,Bus	Line
Definition of the positive direction of the fourth current, given as normal or inverted			
CT4_Ch4Dir_EPar_	Direction I4	Normal,Inverted	Normal

Table 3-148 The enumerated parameters of the current input function

Floating point parameters

Parameter name	Title	Dim.	Min	Max	Default
Rated primary current of channel1					
CT4_Pril1_FPar_	Rated Primary I1	A	100	4000	1000
Rated primary current of channel2					
CT4_Pril2_FPar	Rated Primary I2	A	100	4000	1000
Rated primary current of channel3					
CT4_Pril3_FPar_	Rated Primary I3	A	100	4000	1000
Rated primary current of channel4					
CT4_Pril4_FPar_	Rated Primary I4	A	100	4000	1000

Table 3-149 The floating point parameters of the current input function

NOTE: The rated primary current of the channels is not needed for the current input function block itself. These values are passed on to the subsequent function blocks.

The **measured values** of the current input function block.

Measured value	Dim.	Explanation
Current Ch - I1	A(secondary)	Fourier basic component of the current in channel IL1
Angle Ch - I1	degree	Vector position of the current in channel IL1
Current Ch - I2	A(secondary)	Fourier basic component of the current in channel IL2
Angle Ch - I2	degree	Vector position of the current in channel IL2
Current Ch - I3	A(secondary)	Fourier basic component of the current in channel IL3
Angle Ch - I3	degree	Vector position of the current in channel IL3
Current Ch - I4	A(secondary)	Fourier basic component of the current in channel I4
Angle Ch - I4	degree	Vector position of the current in channel I4

Table 3-150 The measured analogue values of the current input function

NOTE1: The scaling of the Fourier basic component is such that if pure sinusoid 1A RMS of the rated frequency is injected, the displayed value is 1A. (The displayed value does not depend on the parameter setting values "Rated Secondary".)

NOTE2: The reference of the vector position depends on the device configuration. If a voltage input module is included, then the reference vector (vector with angle 0 degree) is the vector calculated for the first voltage input channel of the first applied voltage input module. If no voltage input module is configured, then the reference vector (vector with angle 0 degree) is the vector calculated for the first current input channel of the first applied current input module.

Figure 3-16 shows an example of how the calculated Fourier components are displayed in the on-line block. (See the document “EuroProt+ Remote user interface description”.)

[-] CT4 module		
Current Ch - I1	<input type="text" value="0.84"/>	A
Angle Ch - I1	<input type="text" value="-9"/>	deg
Current Ch - I2	<input type="text" value="0.84"/>	A
Angle Ch - I2	<input type="text" value="-129"/>	deg
Current Ch - I3	<input type="text" value="0.85"/>	A
Angle Ch - I3	<input type="text" value="111"/>	deg
Current Ch - I4	<input type="text" value="0.00"/>	A
Angle Ch - I4	<input type="text" value="0"/>	deg

Figure 3-16 Example: On-line displayed values for the current input module

3.3.2 Voltage input function (VT4)

If the factory configuration includes a voltage transformer hardware module, the voltage input function block is automatically configured among the software function blocks. Separate voltage input function blocks are assigned to each voltage transformer hardware module.

A voltage transformer hardware module is equipped with four special intermediate voltage transformers. (See Chapter 6 of the EuroProt+ hardware description document.) As usual, the first three voltage inputs receive the three phase voltages (UL1, UL2, UL3), the fourth input is reserved for zero sequence voltage or for a voltage from the other side of the circuit breaker for synchron switching. All inputs have a common parameter for type selection: 100V or 200V.

Additionally, there is a correction factor available if the rated secondary voltage of the main voltage transformer (e.g. 110V) does not match the rated input of the device.

The role of the voltage input function block is to

- set the required parameters associated to the voltage inputs,
- deliver the sampled voltage values for disturbance recording,
- perform the basic calculations
 - Fourier basic harmonic magnitude and angle,
 - True RMS value;
- provide the pre-calculated voltage values to the subsequent software modules,
- deliver the basic calculated values for on-line displaying.

Operation of the voltage input algorithm

The voltage input function block receives the sampled voltage values from the internal operating system. The scaling (even hardware scaling) depends on parameter setting. See the parameter VT4_Type_EPar_ (Range). The options to choose from are 100V or 200V. This parameter influences the internal number format and, naturally, accuracy. (A small voltage is processed with finer resolution if 100V is selected.)

The connection of the first three VT secondary winding must be set to reflect actual physical connection. The associated parameter is VT4_Ch13Nom_EPar_ (Connection U1-3). The selection can be: Ph-N, Ph-Ph or Ph-N-Isolated.

The Ph-N option is applied in solidly grounded networks, where the measured phase voltage is never above $1.5 \cdot U_n$. In this case the primary rated voltage of the VT must be the value of the rated PHASE-TO-NEUTRAL voltage.

The Ph-N option is applied in compensated or isolated networks, where the measured phase voltage can be above $1.5 \cdot U_n$ even in normal operation. In this case the primary rated voltage of the VT must be the value of the rated PHASE-TO-PHASE voltage.

If phase-to-phase voltage is connected to the VT input of the device, then the Ph-Ph option is to be selected. Here, the primary rated voltage of the VT must be the value of the rated PHASE-TO-PHASE voltage. This option must not be selected if the distance protection function is supplied from the VT input.

The fourth input is reserved for zero sequence voltage or for a voltage from the other side of the circuit breaker for synchron switching. Accordingly, the connected voltage must be identified with parameter setting VT4_Ch4Nom_EPar_ (Connection U4). Here, phase-to-neutral or phase-to-phase voltage can be selected: Ph-N, Ph-Ph

If needed, the phase voltages can be inverted by setting the parameter VT4_Ch13Dir_EPar_ (Direction U1-3). This selection applies to each of the channels UL1, UL2 and UL3. The fourth voltage channel can be inverted by setting the parameter VT4_Ch4Dir_EPar_ (Direction U4). This inversion may be needed in protection functions such as distance protection, differential protection or for any functions with directional decision, or for checking the voltage vector positions.

Additionally, there is a correction factor available if the rated secondary voltage of the main voltage transformer (e.g. 110V) does not match the rated input of the device. The related parameter is VT4_CorrFact_IPar_ (VT correction). As an example: if the rated secondary voltage of the main voltage transformer is 110V, then select Type 100 for the parameter "Range" and the required value to set here is 110%.

These sampled values are available for further processing and for disturbance recording.

The performed basic calculation results the Fourier basic harmonic magnitude and angle and the true RMS value of the voltages. These results are processed by subsequent protection function blocks and they are available for on-line displaying as well.

The function block also provides parameters for setting the primary rated voltages of the main voltage transformer. This function block does not need that parameter setting. These values are passed on to function blocks such as displaying primary measured values, primary power calculation, etc. Concerning the rated voltage, see the instructions related to the parameter for the connection of the first three VT secondary winding.

Parameters

Enumerated parameters

Parameter name	Title	Selection range	Default
Rated secondary voltage of the input channels. 100 V or 200V is selected by parameter setting, no hardware modification is needed.			
VT4_Type_EPar_	Range	Type 100,Type 200	Type 100
Connection of the first three voltage inputs (main VT secondary)			
VT4_Ch13Nom_EPar_	Connection U1-3	Ph-N, Ph-Ph, Ph-N-Isolated	Ph-N
Selection of the fourth channel input: phase-to-neutral or phase-to-phase voltage			
VT4_Ch4Nom_EPar_	Connection U4	Ph-N,Ph-Ph	Ph-Ph
Definition of the positive direction of the first three input channels, given as normal or inverted			
VT4_Ch13Dir_EPar_	Direction U1-3	Normal,Inverted	Normal
Definition of the positive direction of the fourth voltage, given as normal or inverted			
VT4_Ch4Dir_EPar_	Direction U4	Normal,Inverted	Normal

Table 3-151 The enumerated parameters of the voltage input function

Integer parameter

Parameter name	Title	Unit	Min	Max	Step	Default
Voltage correction						
VT4_CorrFact_IPar_	VT correction	%	100	115	1	100

Table 3-152 The integer parameter of the voltage input function

Floating point parameters

Parameter name	Title	Dim.	Min	Max	Default
Rated primary voltage of channel1					
VT4_PriU1_FPar	Rated Primary U1	kV	1	1000	100
Rated primary voltage of channel2					
VT4_PriU2_FPar	Rated Primary U2	kV	1	1000	100
Rated primary voltage of channel3					
VT4_PriU3_FPar	Rated Primary U3	kV	1	1000	100
Rated primary voltage of channel4					
VT4_PriU4_FPar	Rated Primary U4	kV	1	1000	100

Table 3-153 The floating point parameters of the voltage input function

NOTE: The rated primary voltage of the channels is not needed for the voltage input function block itself. These values are passed on to the subsequent function blocks.

Function	Range	Accuracy
Voltage accuracy	30% ... 130%	< 0.5 %

Table 3-154 Technical data of the voltage input

Measured values

Measured value	Dim.	Explanation
Voltage Ch - U1	V(secondary)	Fourier basic component of the voltage in channel UL1
Angle Ch - U1	degree	Vector position of the voltage in channel UL1
Voltage Ch - U2	V(secondary)	Fourier basic component of the voltage in channel UL2
Angle Ch - U2	degree	Vector position of the voltage in channel UL2
Voltage Ch - U3	V(secondary)	Fourier basic component of the voltage in channel UL3
Angle Ch - U3	degree	Vector position of the voltage in channel UL3
Voltage Ch - U4	V(secondary)	Fourier basic component of the voltage in channel UL4
Angle Ch - U4	degree	Vector position of the voltage in channel UL4

Table 3-155 The measured analogue values of the voltage input function

NOTE1: The scaling of the Fourier basic component is such if pure sinusoid 57V RMS of the rated frequency is injected, the displayed value is 57V. (The displayed value does not depend on the parameter setting values "Rated Secondary".)

NOTE2: The reference vector (vector with angle 0 degree) is the vector calculated for the first voltage input channel of the first applied voltage input module.

The figure below shows an example of how the calculated Fourier components are displayed in the on-line block. (See the document EuroProt+ "Remote user interface description".)

[-] VT4 module		
Voltage Ch - U1	<input type="text" value="56.75"/>	V
Angle Ch - U1	<input type="text" value="0"/>	deg
Voltage Ch - U2	<input type="text" value="51.46"/>	V
Angle Ch - U2	<input type="text" value="-112"/>	deg
Voltage Ch - U3	<input type="text" value="60.54"/>	V
Angle Ch - U3	<input type="text" value="128"/>	deg
Voltage Ch - U4	<input type="text" value="0.00"/>	V
Angle Ch - U4	<input type="text" value="0"/>	deg

Figure 3-17 Example: On-line displayed values for the voltage input module

3.3.3 Line measurement function (MXU)

The measurement

The input values of the EuroProt+ devices are the secondary signals of the voltage transformers and those of the current transformers.

These signals are pre-processed by the “Voltage transformer input” function block and by the “Current transformer input” function block. These function blocks are described in separate documents. The pre-processed values include the Fourier basic harmonic phasors of the voltages and currents and the true RMS values. Additionally, it is in these function blocks that parameters are set concerning the voltage ratio of the primary voltage transformers and current ratio of the current transformers.

Based on the pre-processed values and the measured transformer parameters, the “Line measurement” function block calculates - depending on the hardware and software configuration - the primary RMS values of the voltages and currents and some additional values such as active and reactive power, symmetrical components of voltages and currents. These values are available as primary quantities and they can be displayed on the on-line screen of the device or on the remote user interface of the computers connected to the communication network and they are available for the SCADA system using the configured communication system.

Reporting the measured values and the changes

It is usual for the SCADA systems that they sample the measured and calculated values in regular time periods and additionally they receive the changed values as reports at the moment when any significant change is detected in the primary system. The “Line measurement” function block is able to perform such reporting for the SCADA system.

Operation of the line measurement function block

The **inputs** of the line measurement function are

- the Fourier components and true RMS values of the measured voltages and currents,
- frequency measurement,
- parameters.

The **outputs** of the line measurement function are

- displayed measured values,
- reports to the SCADA system.

NOTE: the scaling values are entered as parameter setting for the “Voltage transformer input” function block and for the “Current transformer input” function block.

The measured values

The **measured values** of the line measurement function depend on the hardware configuration. As an example, Table 3-156 shows the list of the measured values available in a configuration for solidly grounded networks.

Measured value	Explanation
MXU_P_OLM_	Active Power – P (Fourier base harmonic value)
MXU_Q_OLM_	Reactive Power – Q (Fourier base harmonic value)
MXU_S_OLM_	Apparent Power – S (Fourier base harmonic value)
MXU_I1_OLM_	Current L1
MXU_I2_OLM_	Current L2
MXU_I3_OLM_	Current L3
MXU_U1_OLM_	Voltage L1
MXU_U2_OLM_	Voltage L2
MXU_U3_OLM_	Voltage L3
MXU_U12_OLM_	Voltage L12
MXU_U23_OLM_	Voltage L23
MXU_U31_OLM_	Voltage L31
MXU_f_OLM_	Frequency

Table 3-156 Example: Measured values in a configuration for solidly grounded networks

Another example is Figure 3-18, where the measured values available are shown as on-line information in a configuration for compensated networks.

[-] Line measurement		
Active Power - P	17967.19	kW
Reactive Power - Q	10414.57	kVAr
Current L1	97	A
Current L2	97	A
Current L3	97	A
Voltage L12	120.0	kV
Voltage L23	120.0	kV
Voltage L31	120.0	kV
Residual Voltage	0.0	kV
Frequency	50.00	Hz

Figure 3-18 Example: Measured values in a configuration for compensated networks

The available quantities are described in the configuration description documents.

Reporting the measured values and the changes

For reporting, additional information is needed, which is defined in parameter setting. As an example, in a configuration for solidly grounded networks the following parameters are available:

Enumerated parameters

Parameter name	Title	Selection range	Default
Selection of the reporting mode for active power measurement			
MXU_PRepMode_EPar_	Operation ActivePower	Off, Amplitude, Integrated	Amplitude
Selection of the reporting mode for reactive power measurement			
MXU_QRepMode_EPar_	Operation ActivePower	Off, Amplitude, Integrated	Amplitude
Selection of the reporting mode for apparent power measurement			
MXU_SRepMode_EPar_	Operation ApparPower	Off, Amplitude, Integrated	Amplitude
Selection of the reporting mode for current measurement			
MXU_IRepMode_EPar_	Operation Current	Off, Amplitude, Integrated	Amplitude
Selection of the reporting mode for voltage measurement			
MXU_URepMode_EPar_	Operation Voltage	Off, Amplitude, Integrated	Amplitude
Selection of the reporting mode for frequency measurement			
MXU_fRepMode_EPar_	Operation Frequency	Off, Amplitude, Integrated	Amplitude

Table 3-157 The enumerated parameters of the line measurement function

The selection of the reporting mode items is explained in Figure 3-19 and in Figure 3-20.

“Amplitude” mode of reporting

If the “Amplitude” mode is selected for reporting, a report is generated if the measured value leaves the deadband around the previously reported value. As an example, Figure 3-19 shows that the current becomes higher than the value reported in “report1” PLUS the Deadband value, this results “report2”, etc.

For this mode of operation, the Deadband parameters are explained in Table 3-158.

The “Range” parameters in Table 3-158 are needed to evaluate a measurement as “out-of-range”.

Floating point parameters

Parameter name	Title	Dim.	Min	Max	Step	Default
Deadband value for the active power						
MXU_PDeadB_FPar_	Deadband value - P	MW	0.1	100000	0.01	10
Range value for the active power						
MXU_PRange_FPar_	Range value - P	MW	1	100000	0.01	500
Deadband value for the reactive power						
MXU_QDeadB_FPar_	Deadband value - Q	MVAr	0.1	100000	0.01	10
Range value for the reactive power						
MXU_QRange_FPar_	Range value - Q	MVAr	1	100000	0.01	500
Deadband value for the apparent power						
MXU_SDeadB_FPar_	Deadband value - S	MVA	0.1	100000	0.01	10
Range value for the apparent power						
MXU_SRange_FPar_	Range value - S	MVA	1	100000	0.01	500
Deadband value for the current						
MXU_IDeadB_FPar_	Deadband value - I	A	1	2000	1	10
Range value for the current						
MXU_IRange_FPar_	Range value - I	A	1	5000	1	500
Deadband value for the phase-to-neutral voltage						
MXU_UPhDeadB_FPar_	Deadband value – U ph-N	kV	0.1	100	0.01	1
Range value for the phase-to-neutral voltage						
MXU_UPhRange_FPar_	Range value – U ph-N	kV	1	1000	0.1	231
Deadband value for the phase-to-phase voltage						
MXU_UPPDeadB_FPar_	Deadband value – U ph-ph	kV	0.1	100	0.01	1
Range value for the phase-to-phase voltage						
MXU_UPPRange_FPar_	Range value – U ph-ph	kV	1	1000	0.1	400
Deadband value for the current						
MXU_fDeadB_FPar_	Deadband value - f	Hz	0.01	1	0.01	0.02
Range value for the current						
MXU_fRange_FPar_	Range value - f	Hz	0.05	10	0.01	5

Table 3-158 The floating-point parameters of the line measurement function

Amplitude

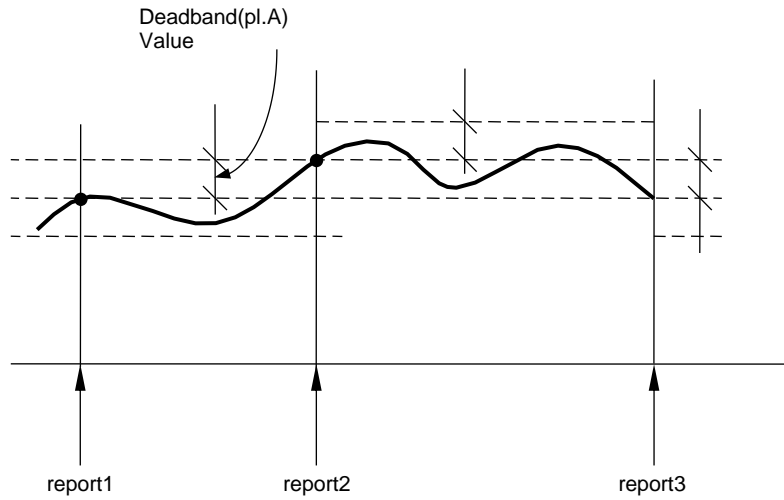

Figure 3-19 Reporting if "Amplitude" mode is selected

"Integral" mode of reporting

If the "Integrated" mode is selected for reporting, a report is generated if the time integral of the measured value since the last report gets becomes larger, in the positive or negative direction, than the (deadband*1sec) area. As an example, Figure 3-20 shows that the integral of the current in time becomes higher than the Deadband value multiplied by 1sec, this results "report2", etc.

Integrated

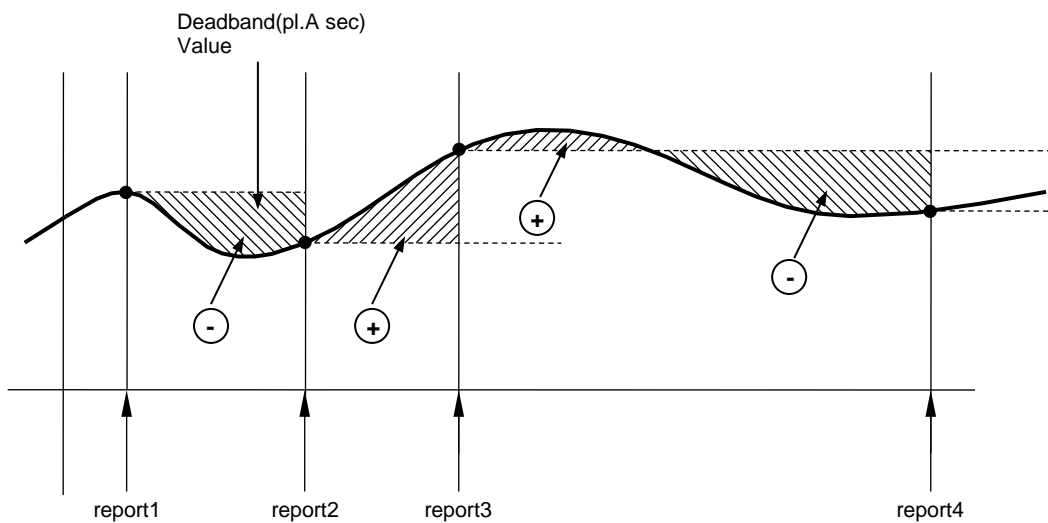

Figure 3-20 Reporting if "Integrated" mode is selected

Periodic reporting

Periodic reporting is generated independently of the changes of the measured values when the defined time period elapses. The required parameter setting is shown in Table 3-159.

Integer parameters

Parameter name	Title	Unit	Min	Max	Step	Default
Reporting time period for the active power						
MXU_PIntPer_IPar_	Report period P	sec	0	3600	1	0
Reporting time period for the reactive power						
MXU_QIntPer_IPar_	Report period Q	sec	0	3600	1	0
Reporting time period for the apparent power						
MXU_SIntPer_IPar_	Report period S	sec	0	3600	1	0
Reporting time period for the voltage						
MXU_UIntPer_IPar_	Report period U	sec	0	3600	1	0
Reporting time period for the current						
MXU_IIntPer_IPar_	Report period I	sec	0	3600	1	0
Reporting time period for the frequency						
MXU_fIntPer_IPar_	Report period f	sec	0	3600	1	0

Table 3-159 The integer parameters of the line measurement function

If the reporting time period is set to 0, then no periodic reporting is performed for this quantity.

All reports can be disabled for a quantity if the reporting mode is set to "Off". See Table 3-157.

Technical data

Function	Range	Accuracy
Current accuracy		
with CT/5151 or CT/5102 modules	0,2 In – 0,5 In	±2%, ±1 digit
	0,5 In – 20 In	±1%, ±1 digit
with CT/1500 module	0,03 In – 2 In	±0,5%, ±1 digit
Voltage accuracy	5 – 150% of Un	±0.5% of Un, ±1 digit
Power accuracy	I > 5% In	±3%, ±1 digit
Frequency accuracy	U > 3.5% Un 45Hz – 55Hz	2mHz

Table 3-160 Technical data of line measurement

3.4 Disturbance recorder

The disturbance recorder function can record analog signals and binary status signals. These signals are configured using the EuroCAP software tool.

The disturbance recorder function has a binary input signal, which serves the purpose of starting the function. **The conditions of starting are defined by the user, applying the graphic equation editor.** The disturbance recorder function keeps on recording during the active state of this signal but the total recording time is limited by the timer parameter setting.

The pre-fault time, max recording time and post-fault time can be defined by parameters.

Mode of recording

If the triggering conditions defined by the user - using the graphic equation editor – are satisfied and the function is enabled by parameter setting, then the disturbance recorder starts recording the sampled values of configured analog signals and binary signals.

The analog signals can be sampled values (voltages and currents) received via input modules or they can be calculated analog values (such as negative sequence components, etc.)

The number of the configured binary signals for recording is limited to 64, and up to 32 analog channels can be recorded.

The available memory for disturbance records is 12 MB.

There are two function blocks available. The first function (**DRE**) applies 20 sampling in a network period. Accordingly for 50 Hz, the sampling frequency is 1 kHz. (For 60 Hz the sampling frequency is 1.2 kHz). This is used in all configurations by default.

The second function (**DRE2**) is capable to be set by parameter to apply 20 or 40 sampling in a network period. This way accordingly for 50 Hz, the sampling frequency is 1 kHz or 2 kHz (and for 60 Hz the sampling frequency is 1.2 kHz or 2.4 kHz). *Except for this, the two function blocks are the same.*

As an example, for 50 Hz, if the duration of the record is 1000 ms then one analog channel needs about 7 kB and a binary channel needs 2 kB, Using the following formula the memory size can be estimated:

$$\text{Memory size of a record} = (n \cdot 7 \text{ kB} + m \cdot 2 \text{ kB}) \cdot \text{record duration (s)}$$

Here n,m: are the number of analog and binary channels respectively.

During the operation of the function, the pre-fault signals are preserved for the time duration as defined by the parameter "PreFault".

The recording duration is limited by the parameter "Max Recording Time" but if the triggering signal resets earlier, this section is shorter.

The post-fault signals are preserved for the time duration as defined by the parameter "PostFault".

During or after the running of the recording, the triggering condition must be reset for a new recording procedure to start.

Format of recording

The records are stored in standard COMTRADE format.

- The configuration is defined by the file .cfg,
- The data are stored in the file .dat,
- Plain text comments can be written in the file .inf.

Downloading and evaluating the disturbance records

The procedure for downloading the records is described in detail in the EuroProt+ manual “Remote user interface description”, Chapter 4.7. The three files are zipped in a file .zip. This procedure assures that the three component files (.cfg, .dat and .inf) are stored in the same location.

The evaluation can be performed using any COMTRADE evaluator software. Protecta offers the “srEval” software for this purpose. The application of this software is described in detail in the “srEval manual”. This manual can be downloaded from the following Internet address: http://www.softreal.hu/product/sreval_en.shtml.

Parameters

Enumerated parameters

Parameter name	Title	Selection range	Default
Parameter for activation			
DRE_Oper_EPar_	Operation	Off, On	Off
DRE_Resolution_EPar_	Resolution *	1/1.2kHz, 2/2.4kHz	1/1.2kHz

*only on the optional 2/2.4 kHz disturbance recorder function

Table 3-161 The enumerated parameter of the disturbance recorder functions

Timer parameters

Parameter name	Title	Unit	Min	Max	Step	Default
Pre-fault time:						
DRE_PreFault_TPar_	PreFault	msec	100	1000	1	200
Post-fault time:						
DRE_PostFault_TPar_	PostFault	msec	100	1000	1	200
Overall-fault time limit:						
DRE_MaxFault_TPar_	Max Recording Time	msec	500	10000	1	1000

Table 3-162 The timer parameters of the disturbance recorder functions

NOTE: The device goes automatically in “Warning” state and sends a warning message (see below) if the sum of the pre-fault time and post-fault time is longer than the overall-fault time. The corresponding message in the RDSP log file is: „Wrong DR settings. PreFault + PostFault must be less than MaxFault. Check the parameters.”

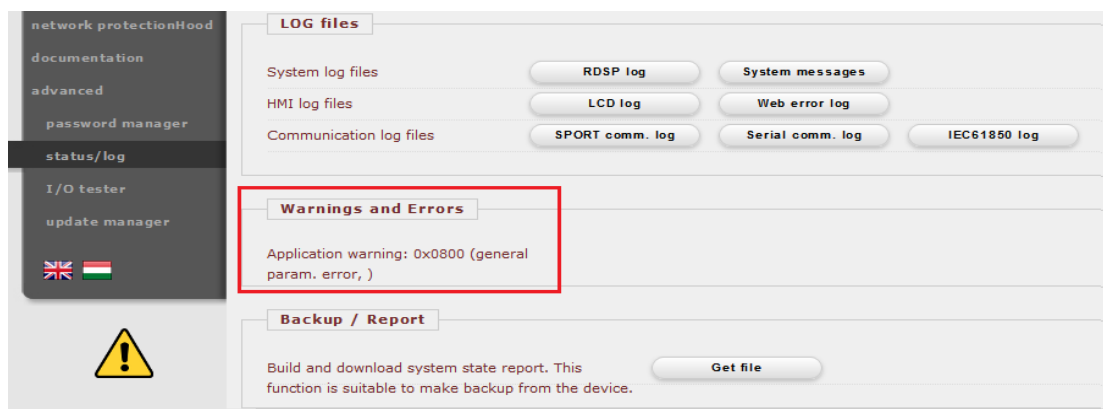

Figure 3-21 Checking the warning message on the status/log page

Binary output status signals

Binary status signal	Explanation
DRE_Start_GrO_	Output status of a graphic equation defined by the user to start the disturbance recorder function.

Table 3-163 The binary input signal of the disturbance recorder functions

The recording is performed if the function is enabled by the parameter setting AND the triggering condition as defined by the user is “True” as well.

The function blocks

The two function blocks of the disturbance recorder function is shown below. The block shows the binary input status signal, which serves the purpose of triggering the record. It is defined by the user in the graphic equation editor.



Figure 3-22 Graphic representations of the disturbance recorder functions

The recorded signals

The analog and binary signals to be recorded are configured using the EuroCAP software tool in the menu item “Software configuration/Disturbance recorder”. (The access level of the user must be at least “Master”.) The application of this software is described in detail in the EuroCAP manual.

3.5 Event recorder

The events of the device and those of the protection functions are recorded with a time stamp of 1 ms time resolution. This information with indication of the generating function can be checked on the touch-screen of the device in the “Events” page, or using an Internet browser of a connected computer.